



General

The series 105 and 200 consist of a broad range of miniature valves and valves with various type of actuation. The connections are M5 for the microvalve series 105 and G 1/8" to G 1" for valve series 200. Due to their special construction with a balanced spool, these valves can be used interchangeably as 3 ways or 5 ways as can be seen in the functional schematics in section 0. This is important because, for example, the 3 ways can be used normally closed or normally open and the 5 ways can be fed through the exhausts 3 and 5 with different pressures according to the need. The spool, as it is moving, isolates the connections without being effected by the inlet pressure.

The polyurethane seals are available for oil free operation. In this case, the ordering code becomes:

238... for G 1/8" - **234...** for G 1/4" - **232...** for G 1/2"

Important: on this type of valves a temperature higher then 40°C along with water or high humidity are causing a progressive reduction of mechanical characteristics of the seals. This chemical reaction (hydrolysis) duration depends by the ambient temperature and in some cases the seal becomes brittle and falls to pieces.

The valves equipped with polyurethane seals are not suitable for tropical climate.

Construction characteristics

	M5	G 1/8" - G 1/4" - G 1/2" - G 1"
Body	Nickel plated brass	Anodized aluminium
Actuators	Nickel plated brass Stainless steel for roller levers and button levers Zinc plated steel for side levers Plastic material for handles, buttons, switches	Anodized aluminium
Seals	Oilproof rubber NBR	Oilproof rubber NBR
Spacer	Acetal resin	Acetal resin (aluminium for G1")
Spool	Nickel plated steel (Kanigen)	Nickel plated steel (Kanigen)
Bottom plates		Acetal resin
Spring	Spring steel	Spring steel











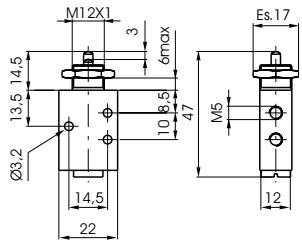

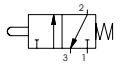
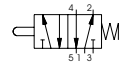
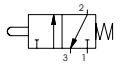
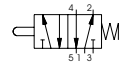
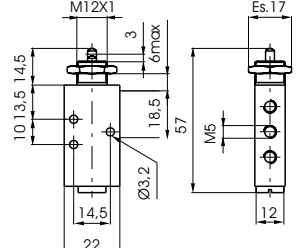

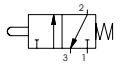
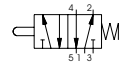
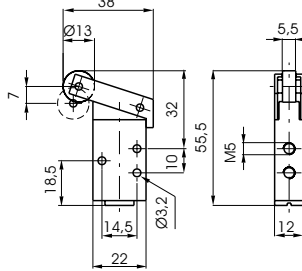

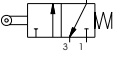

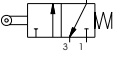

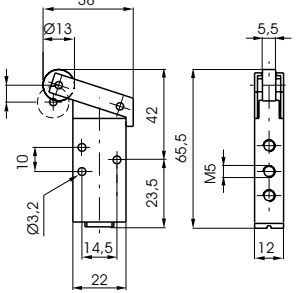

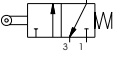

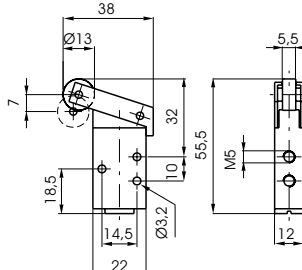

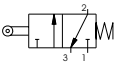
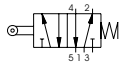
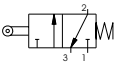
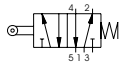
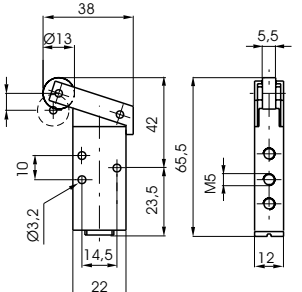

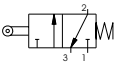
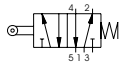
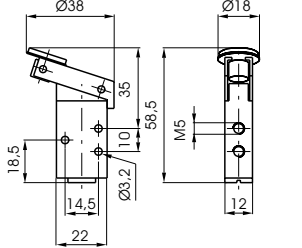
Use and maintenance

These valves have a mean life of 10 to 15 millions of cycles depending on application. Proper lubrication with specified oil reduces dramatically the wear of the seals and good filtration insures long and trouble free operation. Check that the operating conditions are in accordance with the suggested pressure, temperature and so on.

The exhaust ports of the distributor should be protected in a dusty and dirty environment. A spare parts kit including the spool complete of wearing seals and actuators is available for overhauling the valve. This simple operation does not require a skilled worker. Although particular care is needed for assembling the valve.

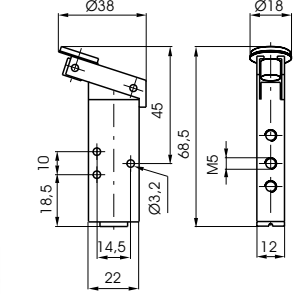
ATTENTION: use hydraulic oil class H for lubrication such as MAGNA GC 32 (Castrol).



<p>3/2</p>  	<p>Tappet spring</p> <hr/> <p>Ordering code</p> <table border="1" style="width: 100%; border-collapse: collapse;"> <tr> <td style="width: 50%; text-align: center;"> <p>105.32.0.1</p>  <p>Weight gr. 70</p> </td> <td style="width: 50%; text-align: center;"> <p>105.52.0.1</p>  <p>Weight gr. 87</p> </td> </tr> </table> <p>Operating force 14 N</p>		<p>105.32.0.1</p>  <p>Weight gr. 70</p>	<p>105.52.0.1</p>  <p>Weight gr. 87</p>	<p>5/2</p>  	
<p>105.32.0.1</p>  <p>Weight gr. 70</p>	<p>105.52.0.1</p>  <p>Weight gr. 87</p>					
<p>3/2</p>  	<p>Lever roller spring</p> <hr/> <p>Ordering code</p> <table border="1" style="width: 100%; border-collapse: collapse;"> <tr> <td style="width: 50%; text-align: center;"> <p>105.32.2.1</p>  <p>Weight gr. 85</p> </td> <td style="width: 50%; text-align: center;"> <p>105.52.2.1</p>  <p>Weight gr. 102</p> </td> </tr> </table> <p>Operating force 6 N</p>		<p>105.32.2.1</p>  <p>Weight gr. 85</p>	<p>105.52.2.1</p>  <p>Weight gr. 102</p>	<p>5/2</p>  	
<p>105.32.2.1</p>  <p>Weight gr. 85</p>	<p>105.52.2.1</p>  <p>Weight gr. 102</p>					
<p>3/2</p>  	<p>Lever roller ball bearing spring</p> <hr/> <p>Ordering code</p> <table border="1" style="width: 100%; border-collapse: collapse;"> <tr> <td style="width: 50%; text-align: center;"> <p>105.32.2.1/1</p>  <p>Weight gr. 100</p> </td> <td style="width: 50%; text-align: center;"> <p>105.52.2.1/1</p>  <p>Weight gr. 117</p> </td> </tr> </table> <p>Operating force 6 N</p>		<p>105.32.2.1/1</p>  <p>Weight gr. 100</p>	<p>105.52.2.1/1</p>  <p>Weight gr. 117</p>	<p>5/2</p>  	
<p>105.32.2.1/1</p>  <p>Weight gr. 100</p>	<p>105.52.2.1/1</p>  <p>Weight gr. 117</p>					
<p>3/2</p>  	<p>Lever button spring</p> <hr/> <p>Ordering code</p> <table border="1" style="width: 100%; border-collapse: collapse;"> <tr> <td style="width: 50%; text-align: center;"> <p>105.32.2.6/1 <i>Red</i></p> <p>105.32.2.6/2 <i>Black</i></p> <p>105.32.2.6/3 <i>Green</i></p>  <p>Weight gr. 85</p> </td> <td style="width: 50%; text-align: center;"> <p>105.52.2.6/1 <i>Red</i></p> <p>105.52.2.6/2 <i>Black</i></p> <p>105.52.2.6/3 <i>Green</i></p>  <p>Weight gr. 102</p> </td> </tr> </table> <p>Operating force 6 N</p>		<p>105.32.2.6/1 <i>Red</i></p> <p>105.32.2.6/2 <i>Black</i></p> <p>105.32.2.6/3 <i>Green</i></p>  <p>Weight gr. 85</p>	<p>105.52.2.6/1 <i>Red</i></p> <p>105.52.2.6/2 <i>Black</i></p> <p>105.52.2.6/3 <i>Green</i></p>  <p>Weight gr. 102</p>	<p>5/2</p>  	
<p>105.32.2.6/1 <i>Red</i></p> <p>105.32.2.6/2 <i>Black</i></p> <p>105.32.2.6/3 <i>Green</i></p>  <p>Weight gr. 85</p>	<p>105.52.2.6/1 <i>Red</i></p> <p>105.52.2.6/2 <i>Black</i></p> <p>105.52.2.6/3 <i>Green</i></p>  <p>Weight gr. 102</p>					
<p>Operational characteristics</p>	<p>Fluid</p> <p>Filtered and lubricated air</p>	<p>Max working pressure</p> <p>10 bar</p>	<p>Operating temperature</p> <p>min. -5°C</p> <p>max. +70°C</p>	<p>Flow rate at 6 bar with $\Delta p = 1$</p> <p>120 NI/min</p>	<p>Ø Orifice size</p> <p>mm 2,5</p>	<p>Working port size</p> <p>M5</p>

3/2 **5/2**

Lever roller, unidirectional spring

Ordering code

105.32.3.1	105.52.3.1
Weight gr. 85	Weight gr. 102

Operating force 6 N

3/2 **5/2**

**Lever panel Ø 22
2-positions**

Ordering code

105.32.4/1 <i>Red</i>	105.52.4/1 <i>Red</i>
105.32.4/2 <i>Black</i>	105.52.4/2 <i>Black</i>
105.32.4/3 <i>Green</i>	105.52.4/3 <i>Green</i>
Weight gr. 125	Weight gr. 142

3/2 **5/2**

**Lever panel Ø 30
2-positions**

Ordering code

105.32.5/1 <i>Red</i>	105.52.5/1 <i>Red</i>
105.32.5/2 <i>Black</i>	105.52.5/2 <i>Black</i>
105.32.5/3 <i>Green</i>	105.52.5/3 <i>Green</i>
Weight gr. 165	Weight gr. 182

3/2 **5/2**

**Push button Ø 30
spring**











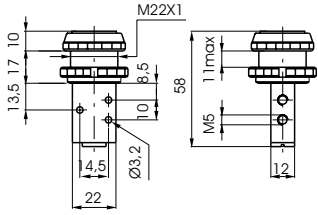



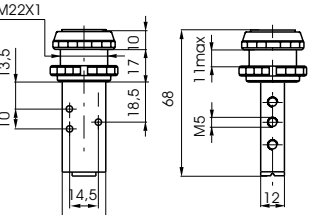

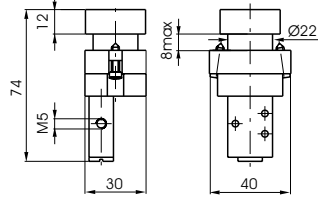

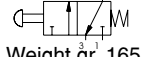

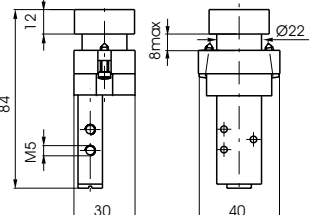
Ordering code

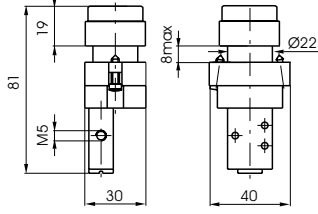
105.32.6.1/1 <i>Red</i>	105.52.6.1/1 <i>Red</i>
105.32.6.1/2 <i>Black</i>	105.52.6.1/2 <i>Black</i>
105.32.6.1/3 <i>Green</i>	105.52.6.1/3 <i>Green</i>
Weight gr. 123	Weight gr. 140

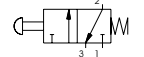
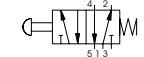
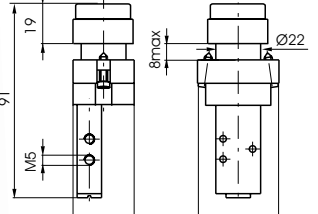
Operating force 14 N

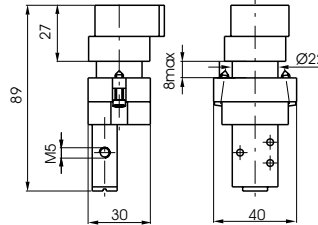
Operational characteristics	Fluid	Max working pressure	Operating temperature		Flow rate at 6 bar with Δ p = 1	Ø Orefice size	Working port size
	Filtered and lubricated air	10 bar	min. -5°C	max. +70°C	120 NI/min	mm 2,5	M5

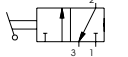
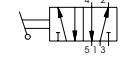
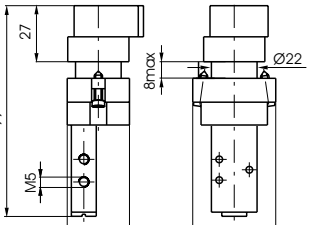

<p>3/2</p>  	<p>Push button Ø 22 spring</p> <hr/> <p>Ordering code</p> <table border="0"> <tr> <td>105.32.6.2/1 <i>Red</i></td> <td>105.52.6.2/1 <i>Red</i></td> </tr> <tr> <td>105.32.6.2/2 <i>Black</i></td> <td>105.52.6.2/2 <i>Black</i></td> </tr> <tr> <td>105.32.6.2/3 <i>Green</i></td> <td>105.52.6.2/3 <i>Green</i></td> </tr> </table>   <p>Weight gr. 102 Weight gr. 119</p> <p>Operating force 14 N</p>		105.32.6.2/1 <i>Red</i>	105.52.6.2/1 <i>Red</i>	105.32.6.2/2 <i>Black</i>	105.52.6.2/2 <i>Black</i>	105.32.6.2/3 <i>Green</i>	105.52.6.2/3 <i>Green</i>	<p>5/2</p>  		
105.32.6.2/1 <i>Red</i>	105.52.6.2/1 <i>Red</i>										
105.32.6.2/2 <i>Black</i>	105.52.6.2/2 <i>Black</i>										
105.32.6.2/3 <i>Green</i>	105.52.6.2/3 <i>Green</i>										
<p>3/2</p>  	<p>Push button spring</p> <hr/> <p>Ordering code</p> <table border="0"> <tr> <td>105.32.6.22/1 <i>Red</i></td> <td>105.52.6.22/1 <i>Red</i></td> </tr> <tr> <td>105.32.6.22/2 <i>Black</i></td> <td>105.52.6.22/2 <i>Black</i></td> </tr> <tr> <td>105.32.6.22/3 <i>Green</i></td> <td>105.52.6.22/3 <i>Green</i></td> </tr> <tr> <td>105.32.6.22/4 <i>Yellow</i></td> <td>105.52.6.22/4 <i>Yellow</i></td> </tr> </table>   <p>Weight gr. 165 Weight gr. 182</p> <p>Operating force 14 N</p>		105.32.6.22/1 <i>Red</i>	105.52.6.22/1 <i>Red</i>	105.32.6.22/2 <i>Black</i>	105.52.6.22/2 <i>Black</i>	105.32.6.22/3 <i>Green</i>	105.52.6.22/3 <i>Green</i>	105.32.6.22/4 <i>Yellow</i>	105.52.6.22/4 <i>Yellow</i>	<p>5/2</p>  
105.32.6.22/1 <i>Red</i>	105.52.6.22/1 <i>Red</i>										
105.32.6.22/2 <i>Black</i>	105.52.6.22/2 <i>Black</i>										
105.32.6.22/3 <i>Green</i>	105.52.6.22/3 <i>Green</i>										
105.32.6.22/4 <i>Yellow</i>	105.52.6.22/4 <i>Yellow</i>										
<p>3/2</p>  	<p>Raised push button spring</p> <hr/> <p>Ordering code</p> <table border="0"> <tr> <td>105.32.6.23/1 <i>Red</i></td> <td>105.52.6.23/1 <i>Red</i></td> </tr> <tr> <td>105.32.6.23/2 <i>Black</i></td> <td>105.52.6.23/2 <i>Black</i></td> </tr> <tr> <td>105.32.6.23/3 <i>Green</i></td> <td>105.52.6.23/3 <i>Green</i></td> </tr> <tr> <td>105.32.6.23/4 <i>Yellow</i></td> <td>105.52.6.23/4 <i>Yellow</i></td> </tr> </table>   <p>Weight gr. 170 Weight gr. 187</p> <p>Operating force 14 N</p>		105.32.6.23/1 <i>Red</i>	105.52.6.23/1 <i>Red</i>	105.32.6.23/2 <i>Black</i>	105.52.6.23/2 <i>Black</i>	105.32.6.23/3 <i>Green</i>	105.52.6.23/3 <i>Green</i>	105.32.6.23/4 <i>Yellow</i>	105.52.6.23/4 <i>Yellow</i>	<p>5/2</p>  
105.32.6.23/1 <i>Red</i>	105.52.6.23/1 <i>Red</i>										
105.32.6.23/2 <i>Black</i>	105.52.6.23/2 <i>Black</i>										
105.32.6.23/3 <i>Green</i>	105.52.6.23/3 <i>Green</i>										
105.32.6.23/4 <i>Yellow</i>	105.52.6.23/4 <i>Yellow</i>										
<p>3/2</p>  	<p>Switch 2-positions</p> <hr/> <p>Ordering code</p> <table border="0"> <tr> <td>105.32.6.27</td> <td>105.52.6.27</td> </tr> </table>   <p>Weight gr. 185 Weight gr. 202</p>		105.32.6.27	105.52.6.27	<p>5/2</p>  						
105.32.6.27	105.52.6.27										
<p>Operational characteristics</p>	<p>Fluid</p> <p>Filtered and lubricated air</p>	<p>Max working pressure</p> <p>10 bar</p>	<p>Operating temperature</p> <p>min. -5°C</p> <p>max. +70°C</p>	<p>Flow rate at 6 bar with Δ p = 1</p> <p>120 NI/min</p>	<p>Ø Orifice size</p> <p>mm 2,5</p>	<p>Working port size</p> <p>M5</p>					

<p>3/2</p>	<p style="text-align: center;">Key switch 2-positions</p> <hr/> <p style="text-align: center;">Ordering code</p> <table border="1" style="width: 100%;"> <tbody> <tr> <td style="width: 50%; text-align: center;"> <p>105.32.6.28</p> <p>Weight gr. 215</p> </td> <td style="width: 50%; text-align: center;"> <p>105.52.6.28</p> <p>Weight gr. 232</p> </td> </tr> </tbody> </table>		<p>105.32.6.28</p> <p>Weight gr. 215</p>	<p>105.52.6.28</p> <p>Weight gr. 232</p>	<p>5/2</p>	
<p>105.32.6.28</p> <p>Weight gr. 215</p>	<p>105.52.6.28</p> <p>Weight gr. 232</p>					
<p>3/2</p>	<p style="text-align: center;">Palm pushbutton Ø 30 spring</p> <hr/> <p style="text-align: center;">Ordering code</p> <table border="1" style="width: 100%;"> <tbody> <tr> <td style="width: 50%; text-align: center;"> <p>105.32.7.1/1 <i>Red</i></p> <p>105.32.7.1/22 <i>Black</i></p> <p>105.32.7.1/3 <i>Green</i></p> <p>Weight gr. 126</p> </td> <td style="width: 50%; text-align: center;"> <p>105.52.7.1/1 <i>Red</i></p> <p>105.52.7.1/22 <i>Black</i></p> <p>105.52.7.1/3 <i>Green</i></p> <p>Weight gr. 143</p> </td> </tr> </tbody> </table> <p style="text-align: center;">Operating force 14 N</p>		<p>105.32.7.1/1 <i>Red</i></p> <p>105.32.7.1/22 <i>Black</i></p> <p>105.32.7.1/3 <i>Green</i></p> <p>Weight gr. 126</p>	<p>105.52.7.1/1 <i>Red</i></p> <p>105.52.7.1/22 <i>Black</i></p> <p>105.52.7.1/3 <i>Green</i></p> <p>Weight gr. 143</p>	<p>5/2</p>	
<p>105.32.7.1/1 <i>Red</i></p> <p>105.32.7.1/22 <i>Black</i></p> <p>105.32.7.1/3 <i>Green</i></p> <p>Weight gr. 126</p>	<p>105.52.7.1/1 <i>Red</i></p> <p>105.52.7.1/22 <i>Black</i></p> <p>105.52.7.1/3 <i>Green</i></p> <p>Weight gr. 143</p>					
<p>3/2</p>	<p style="text-align: center;">Palm pushbutton Ø 22 spring</p> <hr/> <p style="text-align: center;">Ordering code</p> <table border="1" style="width: 100%;"> <tbody> <tr> <td style="width: 50%; text-align: center;"> <p>105.32.7.2/1 <i>Red</i></p> <p>105.32.7.2/2 <i>Black</i></p> <p>105.32.7.2/3 <i>Green</i></p> <p>Weight gr. 103</p> </td> <td style="width: 50%; text-align: center;"> <p>105.52.7.2/1 <i>Red</i></p> <p>105.52.7.2/2 <i>Black</i></p> <p>105.52.7.2/3 <i>Green</i></p> <p>Weight gr. 120</p> </td> </tr> </tbody> </table> <p style="text-align: center;">Operating force 14 N</p>		<p>105.32.7.2/1 <i>Red</i></p> <p>105.32.7.2/2 <i>Black</i></p> <p>105.32.7.2/3 <i>Green</i></p> <p>Weight gr. 103</p>	<p>105.52.7.2/1 <i>Red</i></p> <p>105.52.7.2/2 <i>Black</i></p> <p>105.52.7.2/3 <i>Green</i></p> <p>Weight gr. 120</p>	<p>5/2</p>	
<p>105.32.7.2/1 <i>Red</i></p> <p>105.32.7.2/2 <i>Black</i></p> <p>105.32.7.2/3 <i>Green</i></p> <p>Weight gr. 103</p>	<p>105.52.7.2/1 <i>Red</i></p> <p>105.52.7.2/2 <i>Black</i></p> <p>105.52.7.2/3 <i>Green</i></p> <p>Weight gr. 120</p>					
<p>3/2</p>	<p style="text-align: center;">Push button spring</p> <hr/> <p style="text-align: center;">Ordering code</p> <table border="1" style="width: 100%;"> <tbody> <tr> <td style="width: 50%; text-align: center;"> <p>105.32.8.1/1 <i>Red</i></p> <p>105.32.8.1/2 <i>Black</i></p> <p>105.32.8.1/3 <i>Green</i></p> <p>Weight gr. 75</p> </td> <td style="width: 50%; text-align: center;"> <p>105.52.8.1/1 <i>Red</i></p> <p>105.52.8.1/2 <i>Black</i></p> <p>105.52.8.1/3 <i>Green</i></p> <p>Weight gr. 92</p> </td> </tr> </tbody> </table> <p style="text-align: center;">Operating force 14 N</p>		<p>105.32.8.1/1 <i>Red</i></p> <p>105.32.8.1/2 <i>Black</i></p> <p>105.32.8.1/3 <i>Green</i></p> <p>Weight gr. 75</p>	<p>105.52.8.1/1 <i>Red</i></p> <p>105.52.8.1/2 <i>Black</i></p> <p>105.52.8.1/3 <i>Green</i></p> <p>Weight gr. 92</p>	<p>5/2</p>	
<p>105.32.8.1/1 <i>Red</i></p> <p>105.32.8.1/2 <i>Black</i></p> <p>105.32.8.1/3 <i>Green</i></p> <p>Weight gr. 75</p>	<p>105.52.8.1/1 <i>Red</i></p> <p>105.52.8.1/2 <i>Black</i></p> <p>105.52.8.1/3 <i>Green</i></p> <p>Weight gr. 92</p>					
<p>Operational characteristics</p>	<p>Fluid</p> <p>Filtered and lubricated air</p>	<p>Max working pressure</p> <p>10 bar</p>	<p>Operating temperature</p> <p>min. -5°C</p> <p>max. +70°C</p>	<p>Flow rate at 6 bar with $\Delta p = 1$</p> <p>120 NI/min</p>	<p>Ø Orefice size</p> <p>mm 2,5</p>	<p>Working port size</p> <p>M5</p>



3/2

**Push button
2-positions**

5/2

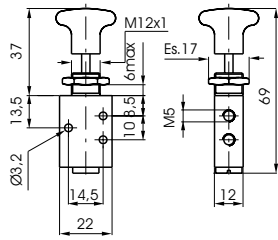

Ordering code

105.32.8/1
Red
105.32.8/2
Black
105.32.8/3
Green

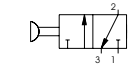

Weight gr. 75

105.52.8/1
Red
105.52.8/2
Black
105.52.8/3
Green

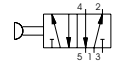

Weight gr. 92

Operating force 3 N

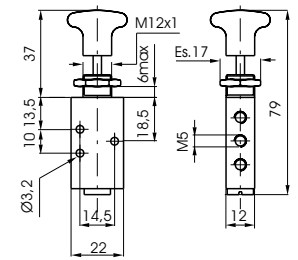

3/2

**Whisker
spring**

5/2

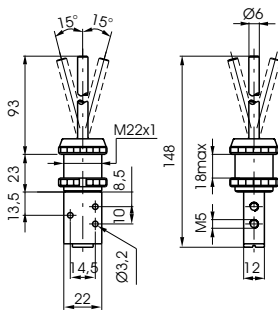

Ordering code

105.32.9.1

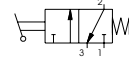

Weight gr. 136

105.52.9.1

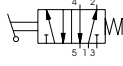

Weight gr. 153

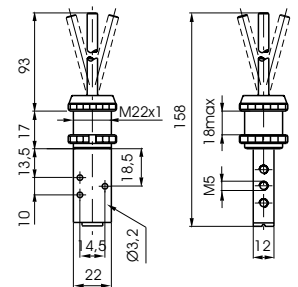

3/2

**Handle
with valve 3/2**

5/2



Ordering code

105.32.6.40A N.O.

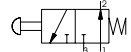

105.32.6.40C N.C.

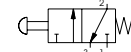

Weight gr. 165

Operating force 14 N

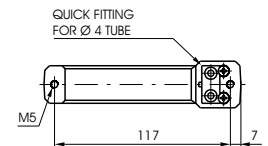
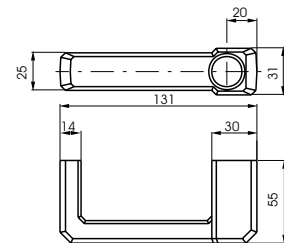

QUICK FITTING
FOR Ø 4 TUBE

Operational characteristics	Fluid	Max working pressure	Operating temperature		Flow rate at 6 bar with $\Delta p = 1$	Ø Orifice size	Working port size
	Filtered and lubricated air	10 bar	min. -5°C	max. +70°C	120 NI/min	mm 2,5	M5 - 4 mm push in fitting