

# COMPACT CYLINDERS

Short stroke compact cylinders	6.0÷6.6
Cylinders with non - rotating device	6.7
Accessories	6.8-6.9
Short stroke compact cylinders with special performance	6.10
<hr/>	
Europe compact cylinders	6.12÷6.15
Variants	6.16
Accessories	6.17÷6.20



## General

Compact or short stroke cylinders meet the need to make clamps that are quite small. In fact, their main characteristic is that their overall dimensions at stroke 0 are very small compared to normal cylinders and therefore can lock or move short distances even in limited spaces.

All this is obtained rationalizing component construction, considering also that the rod guide can be shorter than that of a normal cylinder.

There are various versions: double and single acting, with magnetic piston push-pull rod and as usual they can be easily modified to suit any applications, for example push-pull rod, tandem with opposed rod, tandem push, etc.

They are built so that the cylinder works perfectly, even with non-lubricated air, due to the fact that the seals are self-lubricating and the body is made from anodized shaped aluminium.

On the cylinder body there are cavities where the magnetic sensors are placed.

A complete range of clamps makes them easy to install under any conditions.

It is interesting to note that as these cylinders (from Ø 32 to Ø 100) have anchoring holes with the same lead and thread as those of series 1320 ISO 6431, they accept all mountings except for the intermediate trunnion.

## Construction characteristics

Body	25 micron anodized aluminium alloy
Rod	C43 chromed steel (stainless steel for magnetic cylinders Ø20 and 25)
Piston	aluminium
Rod bushing	anodized aluminium
End plate	anodized aluminium
Piston seal	special NBR 80 shore self-lubricating
Rod seal	self-lubricating polyurethane or VITON®

## Technical characteristics

Fluid	filtered and preferably lubricated air
Max pressure	10 bar
Working temperature	-5°C ÷ +70°C (120° C TEHERBAN® seals)

“Attention : We recommend using dry air if the working temperature is lower than 0°C”

## Standard strokes

**Type 1501, 1504, 1511, 1514, 1515, 1516, 1517 and 1518:**  
for all bores from 5 to 50 mm. every 5 mm.

**Type 1502, 1503, 1512 and 1513:**  
for all bores from 5 to 10 mm.

**Type with non-rotating device:**

Ø 20 and Ø 25	from 5 to 40 mm every 5 mm.
Ø 32 and Ø 40	from 5 to 50 mm every 5 mm.
Ø 50 and Ø 63	from 5 to 60 mm every 5 mm.
Ø 80 and Ø 100	from 5 to 80 mm every 5 mm.



**Drawing**

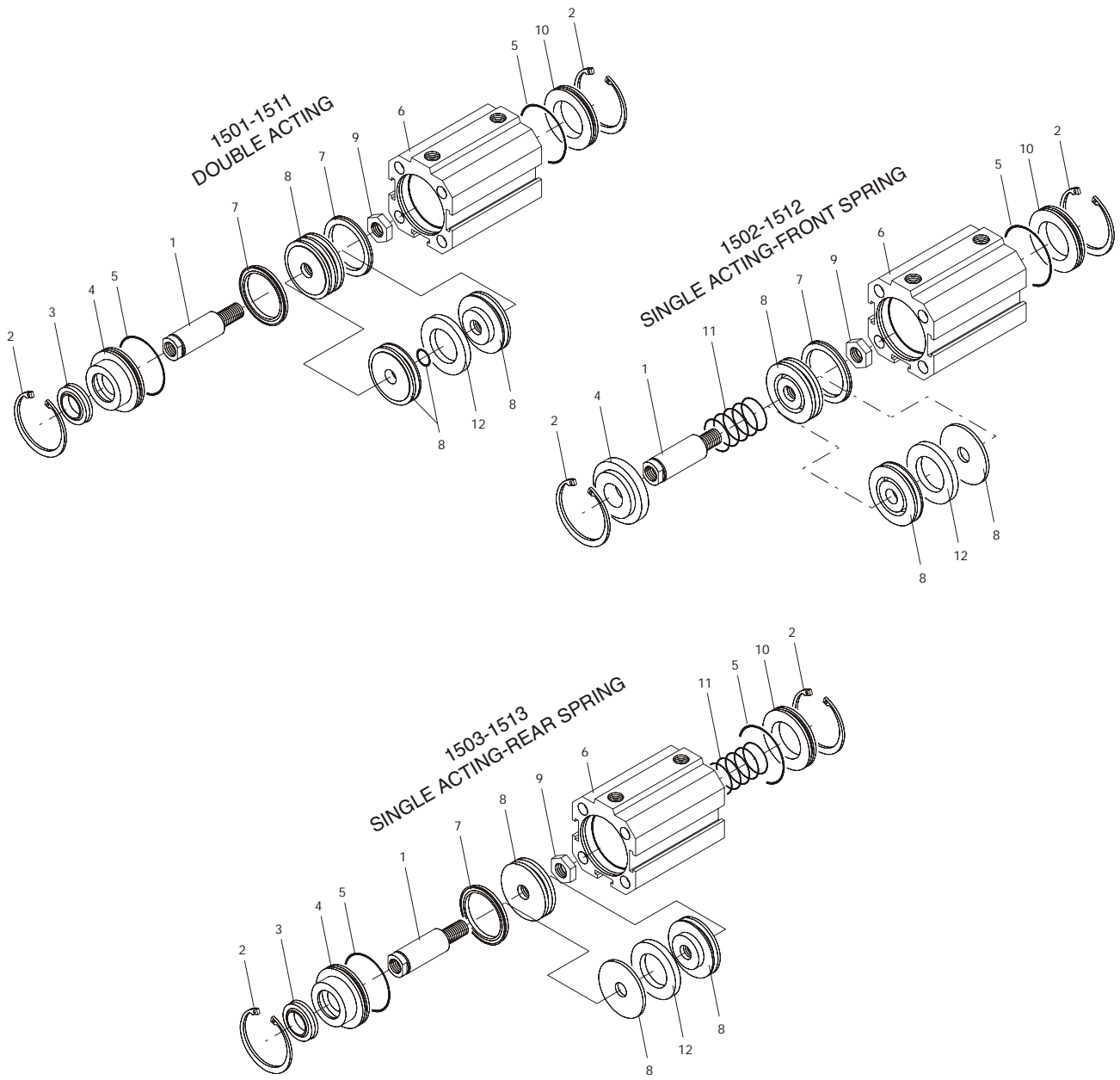

Pos.	Description	N. Pieces
1	Piston rod	1
2	Circlip	2
3	Piston rod seal	1
4	Rod bushing	1
5	Seal	2
6	Cylinder body	1
7	Piston seal	2
8	Piston	1
9	Piston nut	1
10	End plate	1
11	Spring	1
12	Magnet	1

**Double acting version**



Ordering code

**1501.Ø.stroke**

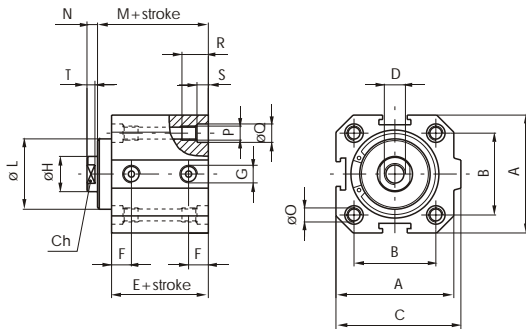

**Double acting version with magnetic piston**



Ordering code

**1511.Ø.stroke**

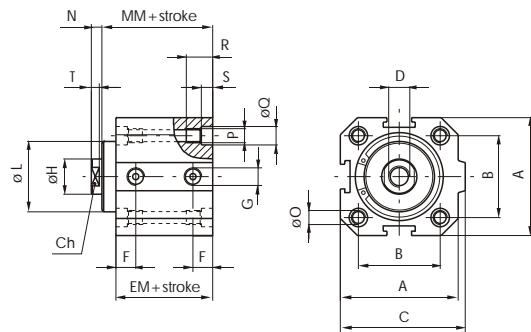

Bore	20	25	32	40	50	63	80	100
A	35	41	48	57	67	80	100	120
B	26	28	32,5	38	46,5	56,5	72	89
C	39,5	44,5	52	61	71	84	106	126
D	M4x8	M5x10	M6x12	M10x15	M12x18	M12x18	M16x20	M16x20
E	29	30,5	32	33,5	35	38	44	47
EM	34	35,5	37	38,5	40	43	49	52
F	9	9,15	9,75	10,5	11	11,25	13,75	15,25
G	G 1/8"	G 1/8"	G 1/8"	G 1/8"	G 1/8"	G 1/8"	G 3/8"	G 3/8"
Ø H	8	10	12	16	20	20	25	25
Ø L $\pm 0,05$ ( $\begin{smallmatrix} 0 \\ -0,1 \end{smallmatrix}$ for Ø80 and Ø 100)	17	20,5	26	31	39	40	55	55
M	32	33	35,5	39,5	43	46	51,5	54,5
MM	37	38	40,5	44,5	48	51	56,5	59,5
N	4	4	4	5	6	6	8	8
Ø O	4,3	5,3	5,3	5,3	7	7	9	9
P	M5	M6	M6	M6	M8	M8	M10	M10
Ø Q	7,5	8,5	8,5	8,5	10,5	10,5	13,5	13,5
R	15	18	18	18	22	22	30	30
S	4,5	5,5	5,5	5,5	6,5	6,5	8,5	8,5
T	3	3	3	4	4,5	4,5	5,5	5,5
Ch	6	8	10	13	17	17	22	22

**Non magnetic**

Weight gr.	stroke 0	75	110	170	260	400	600	800	1500
	every 10 mm.	20	30	40	60	80	100	120	145

**Magnetic**

Weight gr.	stroke 0	90	130	200	310	460	700	910	1620
	every 10 mm.	20	30	40	60	80	100	120	145



**Single acting version with front spring**



Ordering code

**1502.Ø.stroke**

**Single acting version front spring with magnetic piston**



Ordering code

**1512.Ø.stroke**

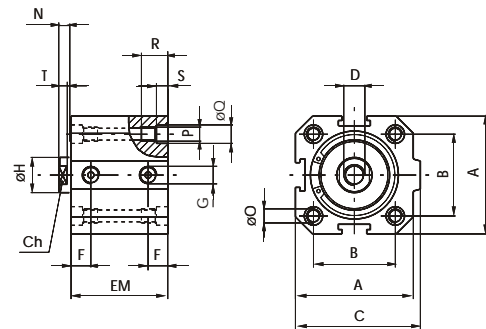
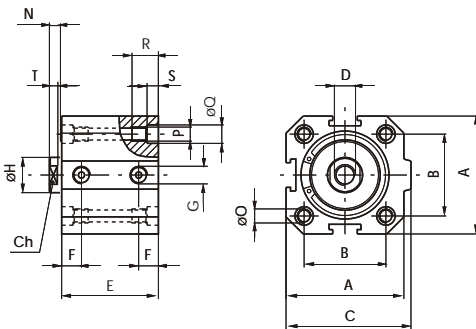

Bore		20	25	32	40	50	63	80	100
A		35	41	48	57	67	80	100	120
B		26	28	32,5	38	46,5	56,5	72	89
C		39,5	44,5	52	61	71	84	106	126
D		M4X8	M5X10	M6X12	M10X15	M12X18	M12X18	M16X20	M16X20
E	stroke 5	29	30,5	32	33,5	35	38	44	47
	stroke 10	34	35,5	37	38,5	40	43	49	52
EM	stroke 5	34	35,5	37	38,5	40	43	49	52
	stroke 10	39	40,5	42	43,5	45	48	54	57
F		9	9,15	9,75	10,5	11	11,25	13,75	15,25
G		G 1/8"	G 1/8"	G 1/8"	G 1/8"	G 1/8"	G 1/8"	G 3/8"	G 3/8"
Ø H		8	10	12	16	20	20	25	25
N		4	4	4	5	6	6	8	8
Ø O		4,3	5,3	5,3	5,3	7	7	9	9
P		M5	M6	M6	M6	M8	M8	M10	M10
Ø Q		7,5	8,5	8,5	8,5	10,5	10,5	13,5	13,5
R		15	18	18	18	22	22	30	30
S		4,5	5,5	5,5	5,5	6,5	6,5	8,5	8,5
T		3	3	3	4	4,5	4,5	5,5	5,5
Ch		6	8	10	13	17	17	22	22

**Non magnetic**

Weight gr.	stroke 0	70	105	160	250	370	550	750	1440
	stroke 10	80	120	180	280	410	600	810	1500

**Magnetic**

Weight gr.	stroke 0	85	125	190	300	430	650	860	1560
	stroke 10	95	140	210	330	470	700	920	1620

**Single acting version with rear spring**



Ordering code

**1503.Ø.stroke**

**Single acting version rear spring with magnetic piston**



Ordering code

**1513.Ø.stroke**

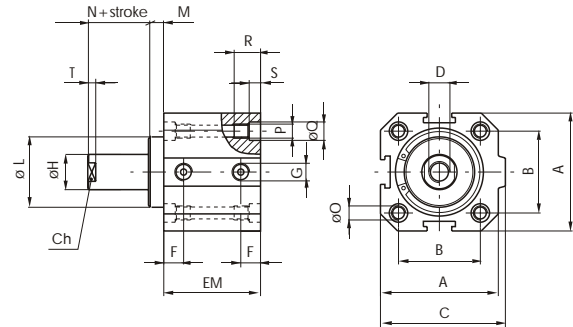
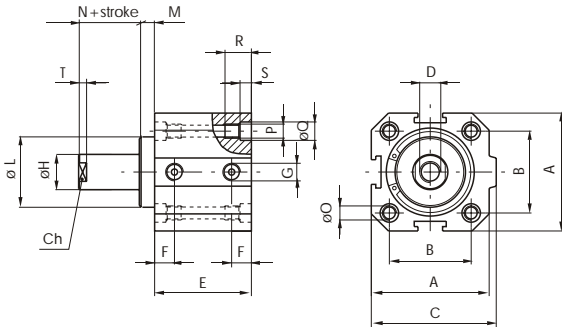

Bore	20	25	32	40	50	63	80	100
A	35	41	48	57	67	80	100	120
B	26	28	32,5	38	46,5	56,5	72	89
C	39,5	44,5	52	61	71	84	106	126
D	M4X8	M5X10	M6X12	M10X15	M12X18	M12X18	M16X20	M16X20
E	stroke 5	29	30,5	32	33,5	35	38	44
	stroke 10	34	35,5	37	38,5	40	43	49
EM	stroke 5	34	35,5	37	38,5	40	43	49
	stroke 10	39	40,5	42	43,5	45	48	54
F	9	9,15	9,75	10,5	11	11,25	13,75	15,25
G	G 1/8"	G 1/8"	G 1/8"	G 1/8"	G 1/8"	G 1/8"	G 3/8"	G 3/8"
Ø H	8	10	12	16	20	20	25	25
Ø L $\pm 0,05$ ( $\begin{smallmatrix} 0 \\ -0,1 \end{smallmatrix}$ for Ø80 and Ø 100)	17	20,5	26	31	39	40	55	55
M	3	2,5	3,5	6	8	8	7,5	7,5
N	4	4	4	5	6	6	8	8
Ø O	4,3	5,3	5,3	5,3	7	7	9	9
P	M5	M6	M6	M6	M8	M8	M10	M10
Ø Q	7,5	8,5	8,5	8,5	10,5	10,5	13,5	13,5
R	15	18	18	18	22	22	30	30
S	4,5	5,5	5,5	5,5	6,5	6,5	8,5	8,5
T	3	3	3	4	4,5	4,5	5,5	5,5
Ch	6	8	10	13	17	17	22	22

**Non magnetic**

Weight gr.	stroke 5	70	105	160	250	370	550	750	1440
	stroke 10	80	120	180	280	410	600	810	1500

**Magnetic**

Weight gr.	stroke 5	85	125	190	300	430	650	860	1560
	stroke 10	95	140	210	330	470	700	920	1620



**Double acting push-pull rod version**



Ordering code

**1504.Ø.stroke**

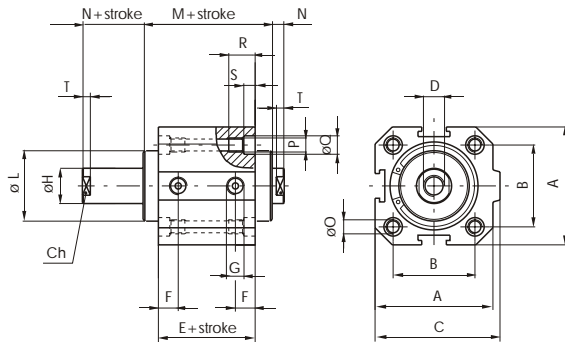

**Double acting push-pull rod version with magnetic piston**



Ordering code

**1514.Ø.stroke**

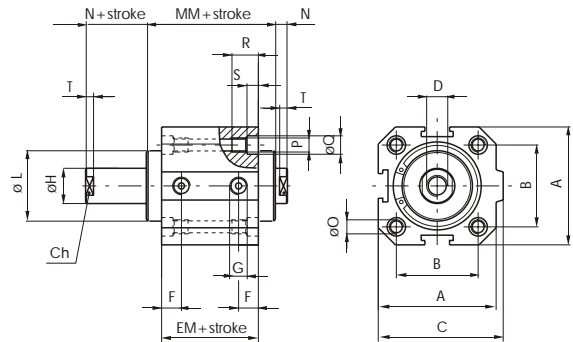

Bore	20	25	32	40	50	63	80	100
A	35	41	48	57	67	80	100	120
B	26	28	32,5	38	46,5	56,5	72	89
C	39,5	44,5	52	61	71	84	106	126
D	M4X8	M5X10	M6X12	M10X15	M12X18	M12X18	M16X20	M16X20
E	29	30,5	32	33,5	35	38	44	47
EM	34	35,5	37	38,5	40	43	49	52
F	9	9,15	9,75	10,5	11	11,25	13,75	15,25
G	G 1/8"	G 1/8"	G 1/8"	G 1/8"	G 1/8"	G 1/8"	G 3/8"	G 3/8"
Ø H	8	10	12	16	20	20	25	25
Ø L $\pm 0,05$ ( $^0_{-0,1}$ for Ø80 and Ø 100)	17	20,5	26	31	39	40	55	55
M	35	35,5	39	45,5	51	54	59	62
MM	40	40,5	44	50,5	56	59	64	67
N	4	4	4	5	6	6	8	8
Ø O	4,3	5,3	5,3	5,3	7	7	9	9
P	M5	M6	M6	M6	M8	M8	M10	M10
Ø Q	7,5	8,5	8,5	8,5	10,5	10,5	13,5	13,5
R	15	18	18	18	22	22	30	30
S	4,5	5,5	5,5	5,5	6,5	6,5	8,5	8,5
T	3	3	3	4	4,5	4,5	5,5	5,5
Ch	6	8	10	13	17	17	22	22

**Non magnetic**

Weight	stroke 0	90	130	200	320	460	670	1100	1680
gr.	stroke 10	20	35	50	70	90	110	155	185

**Magnetic**

Weight	stroke 0	105	160	240	380	530	740	1210	1820
gr.	stroke 10	20	35	50	70	90	110	155	185

**Tandem with opposed rods**

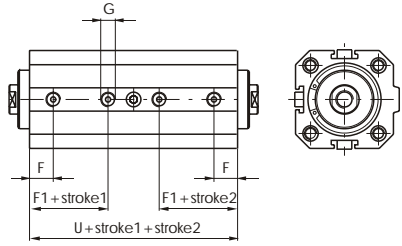

Ordering code

**1515.Ø.stroke 1.stroke 2**  
**1515.Ø.stroke 1.stroke 2.M** (magnetic)

**Tandem push with common rods**

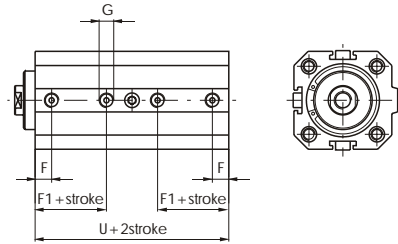

Ordering code

**1516.Ø.stroke**  
**1516.Ø.stroke .M** (magnetic)

**Tandem push with independent rods**

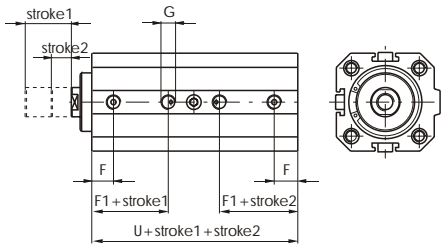

Ordering code

**1517.Ø.stroke 1.stroke 2**  
**1517.Ø.stroke 1.stroke 2.M** (magnetic)

**Opposed tandem with common rods**

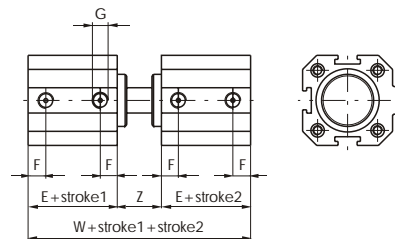

Ordering code

**1518.Ø.stroke 1.stroke 2**  
**1518.Ø.stroke 1.stroke 2.M** (magnetic)

Bore	20	25	32	40	50	63	80	100
E	29	30,5	32	33,5	35	38	44	47
F	9	9,15	9,75	10,5	11	11,25	13,75	15,25
F1	17,5	18,35	19,75	20,5	21,5	24,25	24,75	26,25
G	G 1/8"	G 1/8"	G 1/8"	G 1/8"	G 1/8"	G 1/8"	G 3/8"	G 3/8"
U	59	60,5	67	68,5	70	78	89	97
W	72	74	79	89	98	104	119	125
Z	14	13	15	22	28	28	31	31

**Variations with magnetic piston**

E	34	35,5	37	38,5	40	43	49	52
F1	22,5	23,35	24,75	25,5	26,5	29,25	29,75	31,25
U	69	70,5	77	78,5	80	88	99	107
W	82	84	89	99	108	114	129	135



Cylinders with non-rotating device

Double acting version

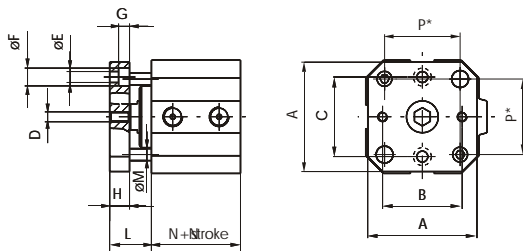

\* = Distance between rods centres

Ordering code  
1501.Ø.stroke.AR

Double version with magnetic piston

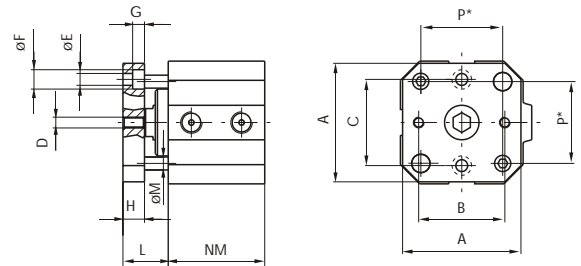

\* = Distance between rods centres

Ordering code  
1511.Ø.stroke.AR

Bore	20	25	32	40	50	63	80	100	
A	35	40	45	55	65	80	100	120	
B	22	26	32	40	50	62	82	103	
C	22	28	34	40	50	62	82	103	
D	M 4	M 5	M 5	M 5	M 6	M 6	M 6	M 8	
Ø E	4,5	5,5	5,5	5,5	6,5	8,5	8,5	8,5	
Ø F	7,5	9	9	9	10,5	13,5	13,5	13,5	
G	4,5	5,5	5,5	5,5	6,5	8,5	8,5	8,5	
H	8	8	10	10	12	12	15	15	
L	15	14,5	17,5	21	26	26	30,5	30,5	
Ø M	6	6	6	6	8	8	10	10	
N	29	30,5	32	33,5	35	38	44	47	
NM	34	35,5	37	38,5	40	43	49	52	
P	26	28	32,5	38	46,5	56,5	72	89	
Max. suggestion stroke	40	40	50	50	60	60	80	80	
Weight gr.	Stroke 0	40	50	70	90	200	250	490	650
	ogni 10 mm	5	5	5	5	10	10	20	20

Rear clevis and rear clevis male

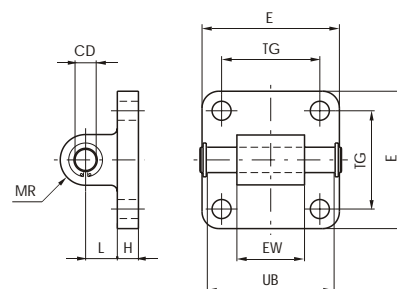
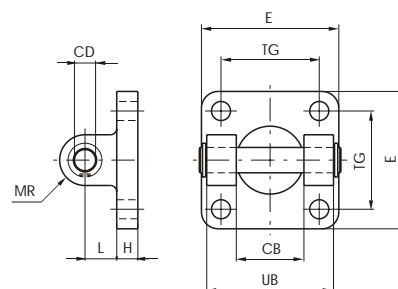

This allows anchorage of the cylinder both parallel and at a right angle to the plane; the cylinder rod can oscillate and self-align as necessary. It is made of aluminium alloy and painted black.

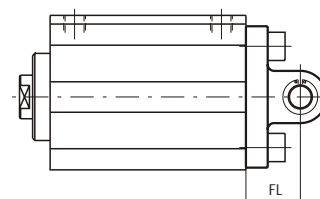

Ordering code  <i>Female</i> <b>1500.Ø.09F</b>  <i>Male</i> <b>1500.Ø.09/1F</b>	Bore	20	25	32	40	50	63	80	100	
	CB (H 14)	16	20	26	28	32	40	50	60	
	Ø CD (h 9)	8	10	10	12	12	16	16	20	
	E	35	40	45	52	65	75	95	115	
	EW $(\begin{smallmatrix} +0.2 \\ -0.6 \end{smallmatrix})$	16	20	26	28	32	40	50	60	
	FL	18	20	22	25	27	32	36	41	
	H	6	8	10	10	12	12	16	16	
	L	12	12	12	15	15	20	20	25	
	MR	8	9	10	12	12	16	16	20	
	TG	26	28	32,5	38	46,5	56,5	72	89	
	UB	35	40	45	52	60	70	90	110	
	Weight gr.	09/F	45	75	80	120	180	300	500	860
		09/1F	53	85	100	160	190	370	560	950



**Slot fixing screws**

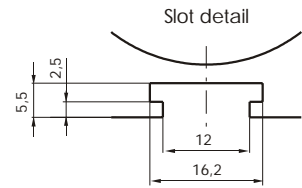
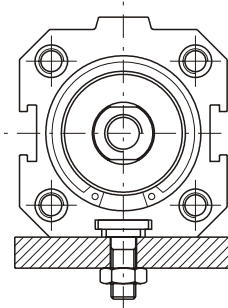
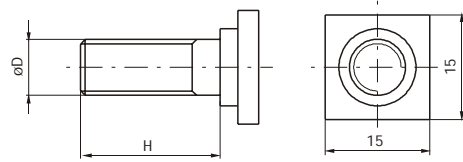

*Example mounted with square headed screws on the plane.*

Bore	20	25	32	40	50	63	80	100
$\varnothing D$	M6	M6	M6	M8	M8	M8	M10	M10
H	15	15	15	20	20	20	25	25
Weight gr.	10			18			25	
Ordering code	<b>1500.15F</b>			<b>1500.16F</b>			<b>1500.18F</b>	

**Nipple with ISO standard thread**

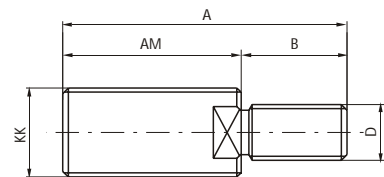

Fitted on the female thread of the compact cylinders, restore the ISO configuration's rod (ISO 6432 for cylinders  $\varnothing 20$  and  $\varnothing 25$ ; ISO 6431 for cylinders from  $\varnothing 32$  to  $\varnothing 100$ ).

Bore	20	25	32	40	50	63	80	100
KK	M8x1,25	M10x1,25	M10x1,25	M12x1,25	M16x1,5	M16x1,5	M20x1,5	M20x1,5
AM	20	22	22	24	32	32	40	40
A	26	30	32	36	47	47	58	58
B	6	8	10	12	15	15	18	18
D	M4	M5	M6	M10	M12	M12	M16	M16
Ordering code	<b>1500.Ø.17F</b>							
Weight gr.	8	15	16	27	65	65	110	110



### General

Besides the standard compact cylinder series, to complete the range, there are also available special versions with smaller diameters. These are used where reduced dimensions and low power are needed. They are manufactured only in a single acting version and the available strokes are those listed under the tables.

### Construction characteristics

Body	anodized aluminium alloy 20011
Rods/Piston	AISI 303 stainless steel chromed rod
Spring	AISI 302 stainless steel
Seals	NBR 80 Shore (lip type)
Bushing guide	brass

### Technical characteristics

Fluid	filtered and lubricated air
Max Pressure	10 bar
Working temperature	-5°C ÷ +70°C

“Attention : We recommend using dry air if the working temperature is lower than 0°C”

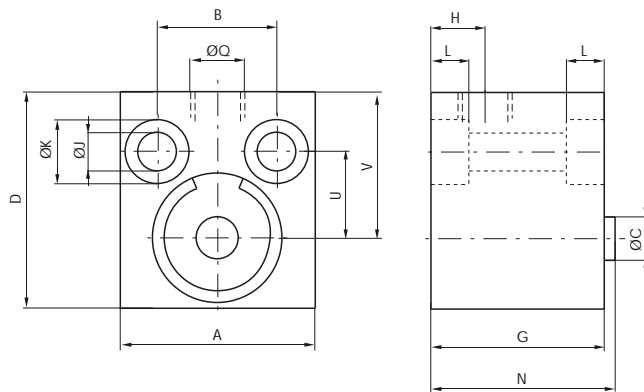

Ordering code

**1502.Ø.stroke**

Bore	Stroke	A	B	C	D	G	H	Ø J	Ø K	L	N	Q	U	V	Weight gr.
8	4	18	11	4	20	16	5,5	3,2	5,7	3	17	M5	8	13,5	16
12	4	20	13	5	25	16	5	3,2	5,7	3	17	M5	9	16	24
12	10	20	13	5	25	26	5	3,2	5,7	3	27	M5	9	16	35
16	4	22	13	6	30	18	5	4,2	7,2	4,5	19	M5	12	20	37
16	8	22	13	6	30	25	5	4,2	7,2	4,5	26	M5	12	20	51