



## General

It is sometimes required that the rod of a cylinder should not turn, in order to be able to keep the load or equipment connected to it in the required position.

We have therefore designed a cylinder that fulfils this purpose through its structural characteristics, namely, by using a barrel and piston with a square section. The rod is of course rigidly connected to the piston, offering good resistance and torsion, while the fit between piston and barrel is very tight. This ensures a rod position accuracy of a few seconds of a degree.

The material used, the accurate machining and careful assembly assure product suitability for exacting applications, replacing costly guide system.

The general characteristics are the same as those of the 1320 series cylinders, according to ISO 6431 standards. Thus, same accessories, mountings and magnetic sensors can be used.

In addition, the high-quality hard anodized aluminium barrel allows the cylinder to operate even without lubrication.

## Construction characteristics

End plates	UNI 5079 aluminium alloy casting painted black by cataphoresis
Rods	C43 chromed steel Ra = 0,2
Barrel	UNI 9006/1 aluminium alloy square section, hardened 30 micron oxidate
Cushion bushings	2011 UNI 9002/5 hardened alloy aluminium
Piston	polyacetal resin, self-lubricated and anti-wear, with plastroferrite rings in magnetic version
Piston seals	80 shore nitril mixture, wear resistant
Rod and cushion seals	90 shore self-lubricating polyurethane mixture
Other seals	in rubber NBR 80 shore
Cushion adjustment screws	in nickel-plated steel

## Technical characteristics

Fluid	filtered and preferably lubricated air
Pressure	10 bar
Operating temperature	-5°C + 70°C

Attention: We recommend using dry air if the working temperature is lower than 0°C.

Bore	Usable surface (square profile) cm <sup>2</sup>	Max couple on the rod (max torque) Nm	Grade precision (rest rod, without load) anti-rotation	Cushion length mm.
32	8,31	0,5	12'	22
40	12,41	0,8	12'	27
50	18,41	1,1	12'	27
63	29,67	1,5	12'	32

### Standard strokes (for all diameters)

from 0 to 150, every 25 mm

### Other stroke for these following bores:

**Ø 32** 80 mm  
**Ø 40** 80 - 160 mm  
**Ø 50** 80 - 160 - 200 - 250 mm  
**Ø 63** 80 - 160 - 200 - 300 - 320 mm

### Stroke Tolerances (ISO 6431)

Bore	Stroke	Tolerance
32 - 40 - 50 - 63	fino a 500	$\begin{matrix} +2 \\ 0 \end{matrix}$

**Drawing**

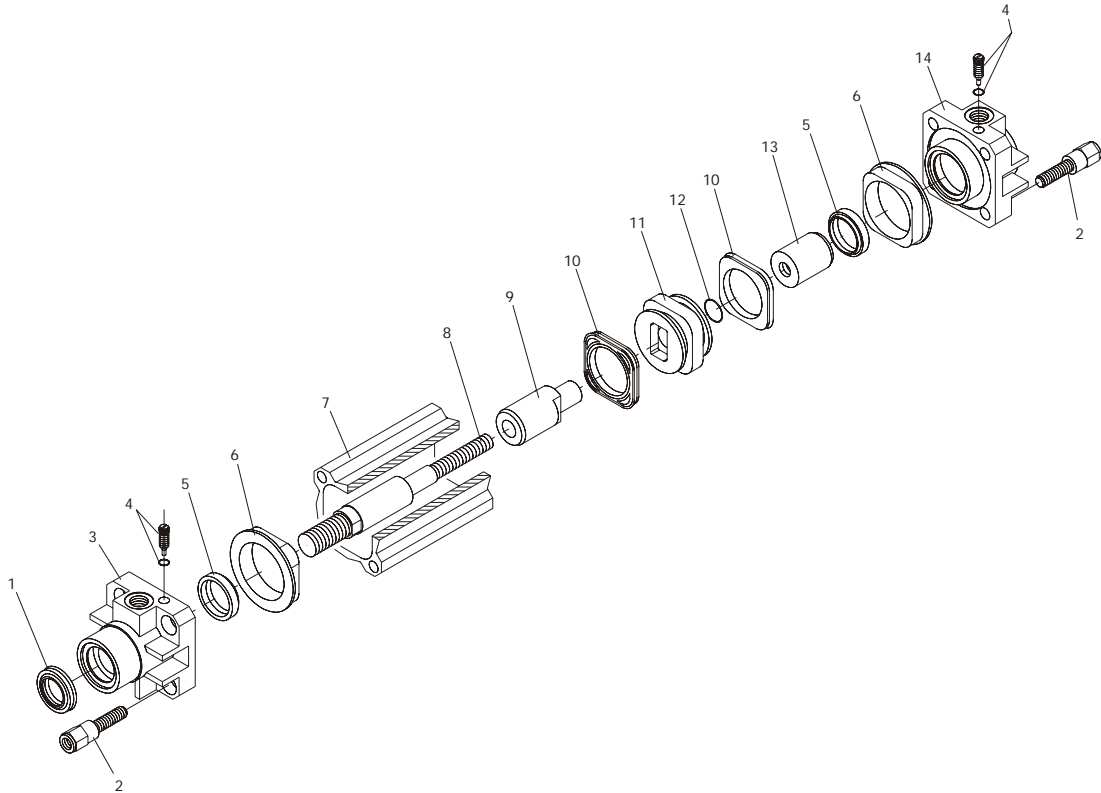

Pos.	Description	N. Pieces
1	Rod seal	1
2	Tie rod nut	8
3	Front cover	1
4	Cushioning adjustment screw	2
5	Cushion seal	2
6	Cover seal	2
7	Barrel	1
8	Rod	1
9	Front bushing cushion	1
10	Piston seal	2
11	Piston	1
12	Bushing-Piston seal	1
13	Rear cushion bushing	1
14	Rear cover	1



**Basic version**

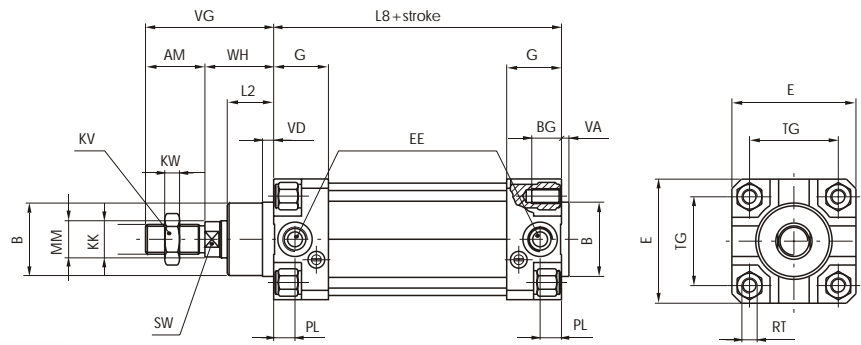

This is the configuration that represents the basic cylinder according to ISO-VDMA standards. It can be directly anchored on machine parts using the four threads on the end cover. For other applications see the following pages where different types of attachments shown.

Bore	32	40	50	63	
AM	22	24	32	32	
B (e 11)	30	35	40	45	
BG	12	12	16	16	
E	46	52	65	75	
EE	G 1/8"	G 1/4"	G 1/4"	G 3/8"	
G	25	29	29,5	36	
KK	M10x1,25	M12x1,25	M16x1,5	M16x1,5	
KV	17	19	24	24	
KW	6	7	8	8	
L 2	18,5	21	26,5	26,5	
L 8	94	105	106	121	
MM	12	16	20	20	
PL	9	11,5	11,5	14	
RT	M6	M6	M8	M8	
SW	10	13	17	17	
TG	32,5	38	46,5	56,5	
VA	4	4	4	4	
VD	5	6	6	6	
VG	48	54	69	69	
WH	26	30	37	37	
Weight gr.	stroke 0	505	705	1320	1710
	every 10 mm	24	33	53	58

Ordering code	
<b>1348.Ø.stroke.01</b>	magnetic chromed rod
<b>1349.Ø.stroke.01</b>	magnetic stainless steel chromed rod
<b>1350.Ø.stroke.01</b>	non-magnetic chromed rod

**Push/pull version**

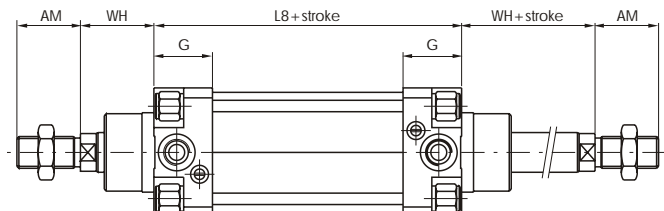

Ordering code	
<b>1348.Ø.stroke.02</b>	magnetic chromed rod
<b>1349.Ø.stroke.02</b>	magnetic stainless steel chromed rod
<b>1350.Ø.stroke.02</b>	non-magnetic chromed rod