

**General**

These rotary actuators transform the linear motion of a piston into the rotary motion of a shaft. The uses in automation are varying and always convenient compares with other solutions.

Considering the bores from Ø 32 to Ø 100 and the wide range of rotary motions (from 1 degree to 360 degrees) it is possible to solve any problems one might have.

As seen from the enlarged diagram, the mechanism is formed by a rack anchored to a piston which transmits the movement to the grooved pinion with torque in proportion to the sections of the cylinders and dimensions of the pinion. Sphere shaped cushions for the pinion and sliding shoe for the cog guarantee a precise and reliable movement over a long period of time.

The box containing the movement is waterproof, protecting the pinion and cog against oxydation. To attach the rotating cylinders threaded holes are provided on the central part for the flange and foot mounts from series 1320 can be used. In the magnetic piston version sensors (from series 1320) can be mounted to reveal the position of the angular movement.

Upon request, rotation angle adjustment registers can be mounted for easier tuning ( $\pm 10$  degrees). The cylinders are cushioned according to the series. For the cylinders without adjustment registers one has to bear in mind that the rotation angle is never perfect and the tolerance is around +1 degree. Also, it must be taken into account that even a minimum play between rack and pinion does not guarantee the repetition of the rotation limit switch.

**Construction characteristics**

Cover plates	UNI 5079 aluminium alloy casting
Central body	oxidized aluminium
Pinion	18 NiCrMo4 cemented and tempered
Rack	C43
Barrel	anodized aluminium RA = 0,3-0,5
Sliding shoe	acetal resin
Cushion bushings	hardened aluminium
Piston	vulcanized NBR 80 shore rubber block on steel core with incorporated permanent magnet NBR 80 shore rubber block without magnet polus rear spacer (for non-magnetic version)
Seals	NBR 80 shore rubber
Cushion adjustment screws	nickel plated steel
Rotating angle adjustment assy	nickel plated brass

**Technical characteristics**

Fluid	filterd and preferably lubricated air
Max pressure	10 bar
Working temperature	-5°C ÷ +70°C
Standard rotation	90° - 180° - 270° - 360°
Rotating angle adjustment	$\pm 10^\circ$

**Attention:** We recommend using dry air if the working temperature is lower than 0°C.

Bore	32	40	50	63	80	100
Torque moments Nm/bar	0,9	1,7	2,9	5,55	13,2	23,8
Axis load max. kg.	8	10	10	12	18	22
Cushioning angle	60°	60°	50°	50°	40°	40°

**Drawing**

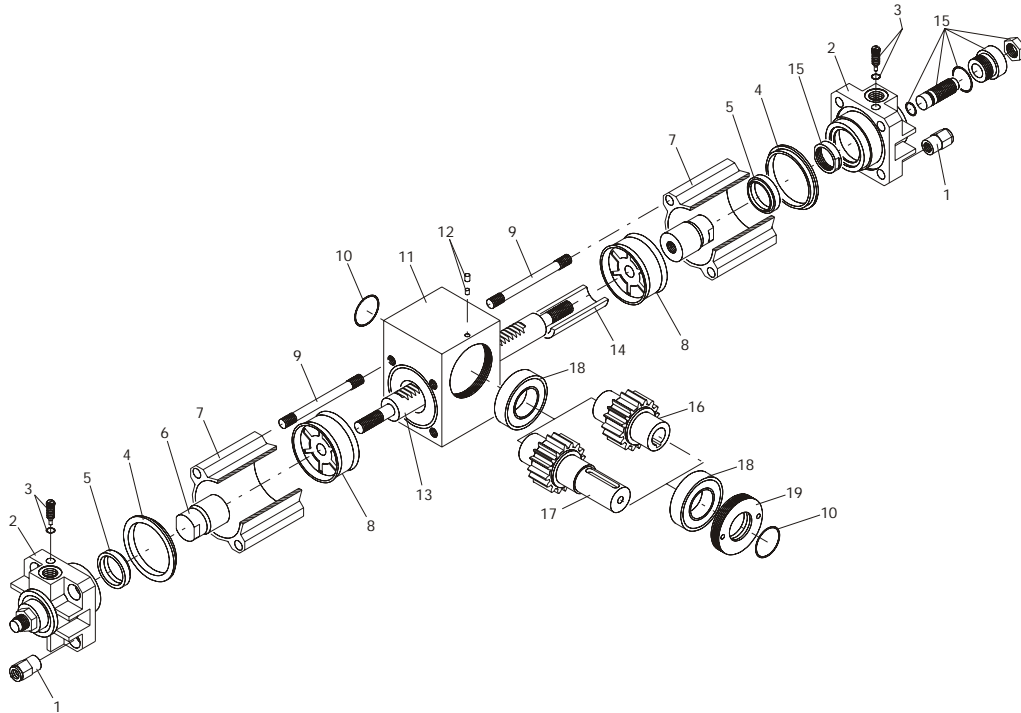

Pos.	Description	N. Pieces
1	Tie rod nut	8
2	End cover	2
3	Cushioning adjustment screw	2
4	Seal cover	2
5	Cushion seal	2
6	Cushion bearing	2
7	Barrel	2
8	Piston	2
9	Tie rod	8
10	Seal	2
11	Body	1
12	Screw plug + Gasket	1
13	Rack	1
14	Sliding shoe	1
15	Adjustment angle	2
16	Female pinion	1
17	Male pinion	1
18	Ball bearing	2
19	Lock nut	1

**Female pinion version**

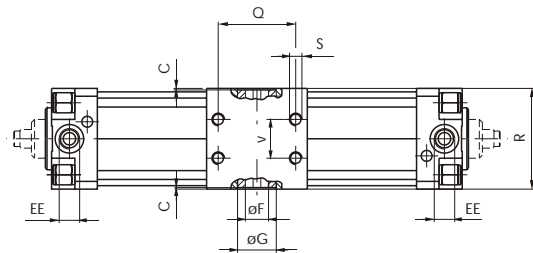
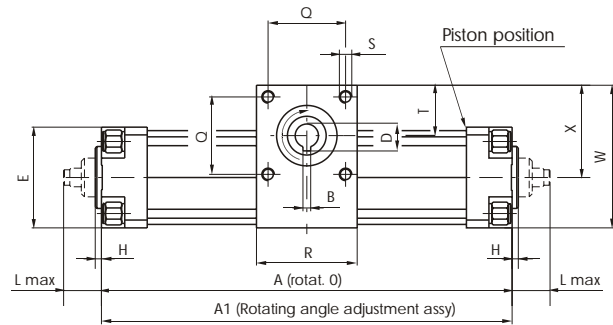

Ordering code
1330.Ø.*.01 magnetic
1331.Ø.*.01 non magnetic
1330.Ø.*.01R magnetic with rotating adjustment angle
1331.Ø.*.01R non magnetic with rotating adjustment angle
* = rotating angle

**Male pinion version**

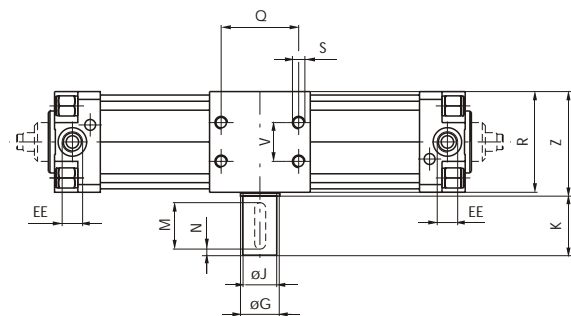
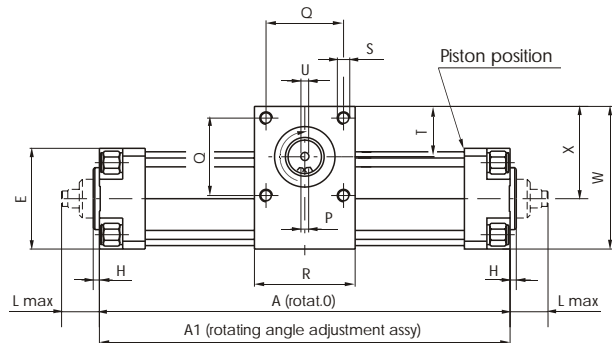

Ordering code
1332.Ø.*.01 magnetic
1333.Ø.*.01 non magnetic
1332.Ø.*.01R magnetic with rotating adjustment angle
1333.Ø.*.01R non magnetic with rotating adjustment angle
* = rotating angle



**Dimensions**

Bore	32	40	50	63	80	100	
A rot. 0°	171	195	202	233	268	300	
A rot. 90°	218	252	265	308	378	427	
A rot. 180°	265	308	328	382	488	555	
A rot. 270°	312	364	390	457	598	682	
A rot. 360°	359	421	453	531	708	809	
A1 rot. 0°	174	198	206	237	274	307	
A1 rot. 90°	221	255	269	312	384	434	
A1 rot. 180°	268	311	332	386	494	562	
A1 rot. 270°	315	367	394	461	604	689	
A1 rot. 360°	362	424	457	535	714	816	
B	5	5	5	6	6	8	
C	1	1	1	1	1	1	
D	17,3	17,3	17,3	20,8	22,8	28,3	
E	46	52	65	75	95	115	
Ø F (H 7)	15	15	15	18	20	25	
Ø G	25	25	25	30	40	55	
H	4	4	4	4	4	4	
Ø J (h 7)	14	14	22	25	30	35	
K	30	30	40	40	50	50	
L max.	23	23	28,5	28,5	34,5	34,5	
M	25	25	35	35	45	45	
N	2,5	2,5	2,5	2,5	2,5	2,5	
P	5	5	6	8	8	10	
Q	33	40	50	60	80	80	
R	50	60	65	75	100	115	
S	M6	M6	M8	M8	M10	M10	
T	27,5	35	32,5	35,5	50	54,5	
U	M5	M5	M6	M8	M8	M10	
V	18	22	25	35	50	60	
W	71	85	92	105	141	162	
X	48	59	59,5	67,5	93,5	104,5	
Z	51	61	66	76	101	116	
EE	G 1/8"	G 1/4"	G 1/4"	G 3/8"	G 3/8"	G 1/2"	
Piston stroke every 10 °of rotation	2,61	3,14	3,49	4,14	6,11	7,07	
Female Pinion weight gr.	rot. 90°	1450	2020	3050	4850	10000	14900
	rot. 180°	1600	2240	3350	5350	11000	16350
	rot. 270°	1750	2460	3650	5850	12000	17800
	rot. 360°	1900	2680	3950	6350	13000	19250
Male Pinion weight gr.	rot. 90°	1550	2150	3280	5150	10500	15700
	rot. 180°	1700	2370	3580	5650	11500	17150
	rot. 270°	1850	2590	3880	6150	12500	18600
	rot. 360°	2000	2810	4180	6650	13500	20050

4

**Magnetic sensors**

Types and codes of the 1320 series.

**Mounting**

Types and codes of the 1320 series