

RODLESS CYLINDERS

Series 1600

General	6.0
Rodless cylinders	6.1÷7.5
Accessories	6.6÷6.9
Cable cylinders	6.10



General

The purpose of producing a rodless cylinder is to provide space saving over conventional cylinders. On a traditional rod type cylinder, the total space occupied with rod out is more than double the length of the cylinder, while with rodless cylinder it's little more than its stroke.

The barrel, made with extruded anodized aluminium, is formed with a longitudinal slot allowing the connection between piston and mounting carriage.

The pneumatic seal is obtained with the use of a hardened stainless steel band, located and retained along the slot with a magnetic field generated by two bands of **plastoferrite**.

Another stainless steel band is positioned outside, closing the slot avoiding contamination to the inner part of the cylinder.

A slide rail system separates the two bands, in the pressure free area between the two piston seals, allowing the movement of the mounting carriage.

The main feature of this cylinder is the robust piston mounting plate system. Guide blocks are oversized to withstand high stress; furthermore, the steel bands system ensures a long cylinder life even with high temperature and speed.

Other important features include the possibility to feed the two cylinder chambers from a single end cap, installation of magnetic piston for controlling the reed contact sensors, adjustable cushioning and simple maintenance procedure. Standard accessories include foot mounting brackets for installation on cylinder and caps, intermediate mounting brackets to give support to long stroke cylinders under load (over one meter), an oscillating coupling device for installation between the mounting plate and the load and on request, a very precise external movement device.

Construction Characteristics

End covers	anodized aluminium alloy 2011
Barrel	extruded anodized aluminium alloy 6060
Bands	tempered stainless steel
Mounting plate	extruded anodized aluminium alloy 6060
Piston	acetal resin
Guide blocks	acetal resin
Cushion bearings	aluminium alloy 2011
Piston seals	special 80 shore nitril mixture, wear resistant
Other seals	NBR oil-resistant rubber

Technical characteristics

Fluid	filtered and lubricated air
Pressure	0,5 ÷ 8 bar
Working temperature	- 5°C ÷ + 70°C
Max. speed	1,5 m/sec. (normal working conditions)
Bores	Ø 25 - 32 - 40 - 50 - 63
Max. stroke	6 m

"Attention: We recommend using dry air if the working temperature is lower than 0°C"

For applications where a low smooth uniform operations speed is required, your specific request on purchase order is needed so that we can use the proper special grease.

Use and maintenance

This type of cylinder, due to its characteristics, has to be used within certain criteria. Correct use will give long and troublefree operation. Filtered and lubricated compressed air reduce seal wear. Verify that the load will not produce unforeseen stresses. Never combine high speed with heavy load. Always support the long stroke cylinder with intermediate brackets and never exceed the specified working conditions.

If maintenance is required, follow the instructions supplied with the repair kit.

Lubricate with hydraulic oils of class H, such as CASTROL type MAGNA GC 32.



Drawing

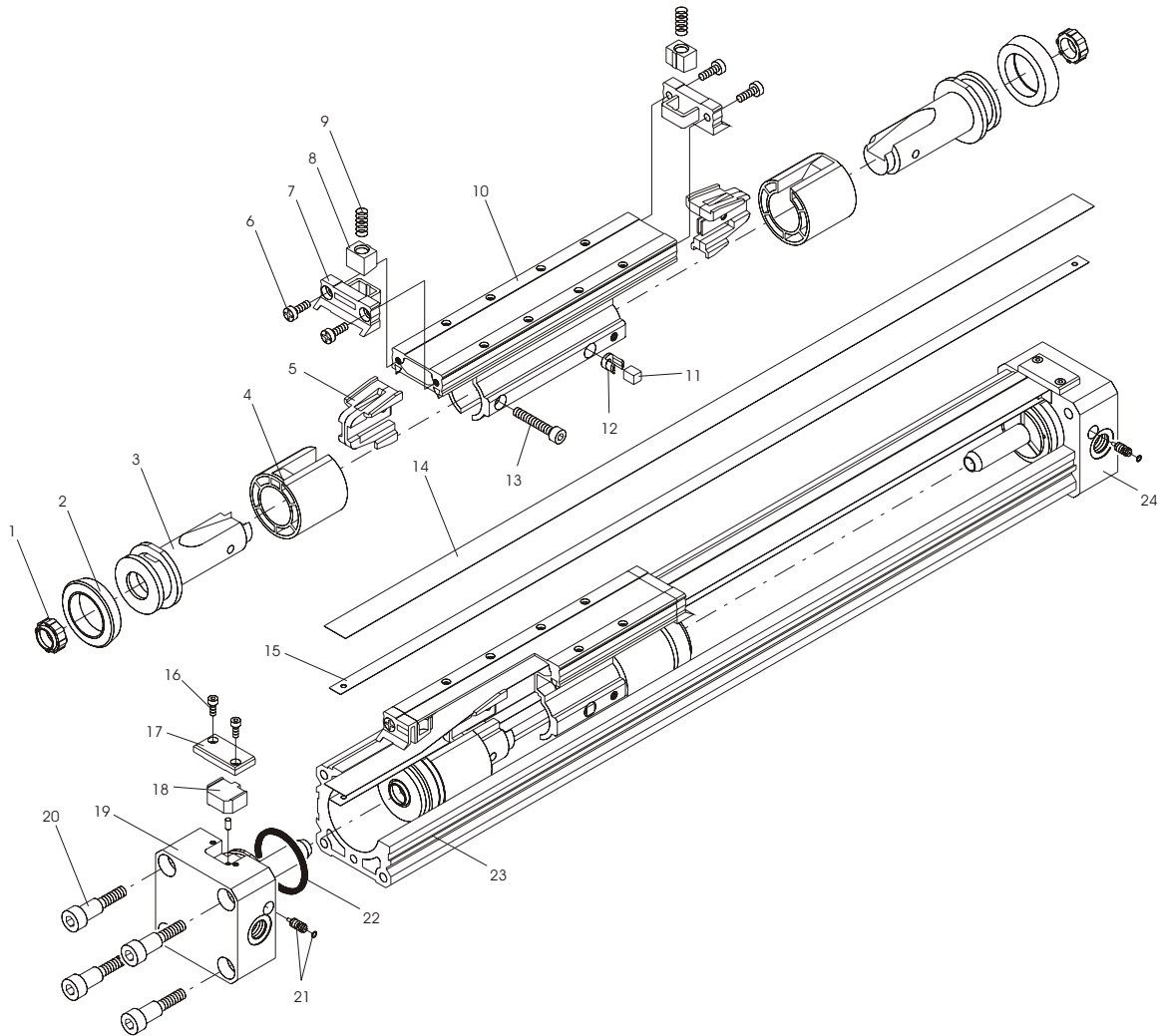

Pos.	Description	N. Pieces	Pos.	Description	N. Pieces
1	Cushion seal	2	13	Screw, piston	2
2	Piston seal	2	14	Band, external	1
3	Piston	2	15	Band, internal	1
4	Guide bearing ring	2	16	Screw, plate	4
5	Band guide	2	17	Plate, upper	2
6	Screw, cover	4	18	Plate, lower	2
7	Cover, mounting plate	2	19	Left end cover	1
8	Band stretcher	2	20	Tie rod	8
9	Spring	2	21	Cushion adj. screw	2
10	Mounting plate	1	22	Seal, end cover	2
11	Magnet	2	23	Barrel	1
12	Bushing, magnet	2	24	Right end cover	1

Basic version

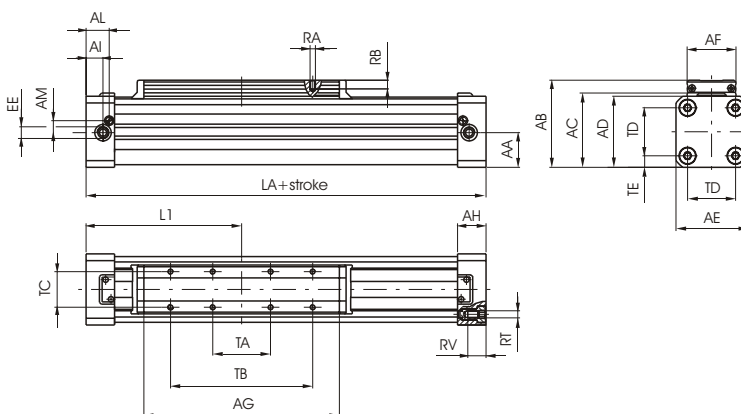

Ordering code

1605.Ø.stroke.01.M

Max. Stroke 6 mt.

Possibility of a single feed cylinder head

Left head

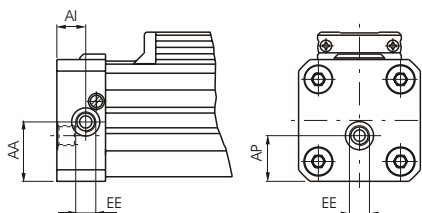

Ordering code

1605.Ø.stroke.02.M

Max. Stroke 6 mt.

Right head

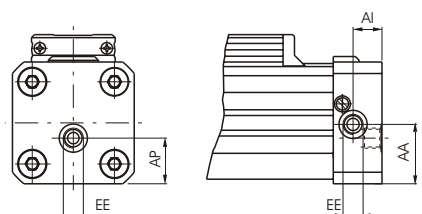

Ordering code

1605.Ø.stroke.03.M

Max. Stroke 6 mt.

Bore	25	32	40	50	63	
AA	19,5	25,5	31	39	46,5	
AB	56	70	80	98	113,5	
AC	48,5	60	70	85	100	
AD	44	55	65	78	95	
AE	40	55	65	78	95	
AF	30	40	40	55	55	
AG	117	146	186	220	255	
AH	23	27	30	32	36	
AI	12,5	14,5	17,5	19	23	
AL	19	22,5	24,5	26	30	
AM	7,5	10,5	11,5	13,5	16	
AP	13	15,2	23	30	35,5	
EE	G 1/8"	G 1/4"	G 1/4"	G 1/4"	G 3/8"	
L1	100	125	150	175	215	
LA	200	250	300	350	430	
RA	M 4	M 5	M 5	M 6	M 6	
RB	7,5	9,5	9,5	11,5	11,5	
RT	M 5	M 6	M 6	M 8	M 8	
RV	13,5	16,5	16,5	20,5	20,5	
TA	30	40	40	65	65	
TB	80	110	110	160	160	
TC	23	30	30	40	40	
TD	27	36	47	54	68	
TE	6,5	9,5	9	12	13,5	
Weight gr.	Stroke 0	900	1650	2650	4330	8010
	every 100 mm.	225	340	490	725	1070
STROKE TOLLERANCE: + 2 mm.						



Cylinder with linear control unit
(Ø 25, Ø32 and Ø40)

Cylinder Ø 25

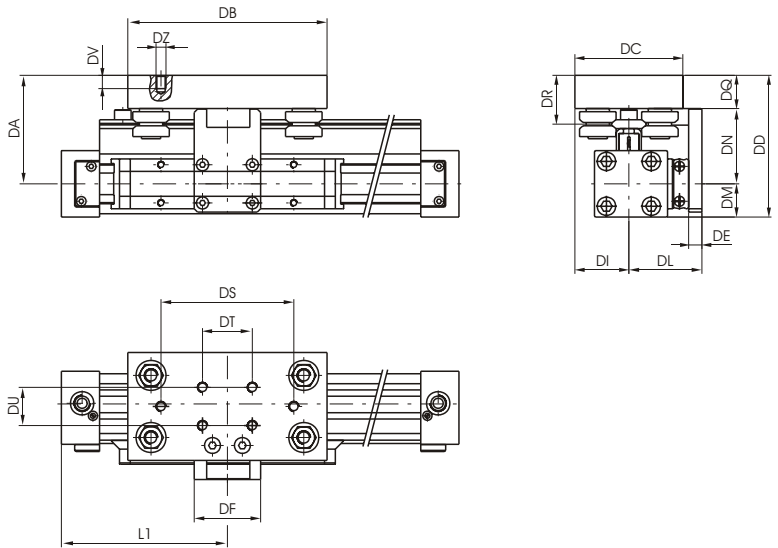

Ordering code
1605.Ø.stroke.01.MG (max. stroke 3 m.)

Cylinder Ø 32, Ø 40

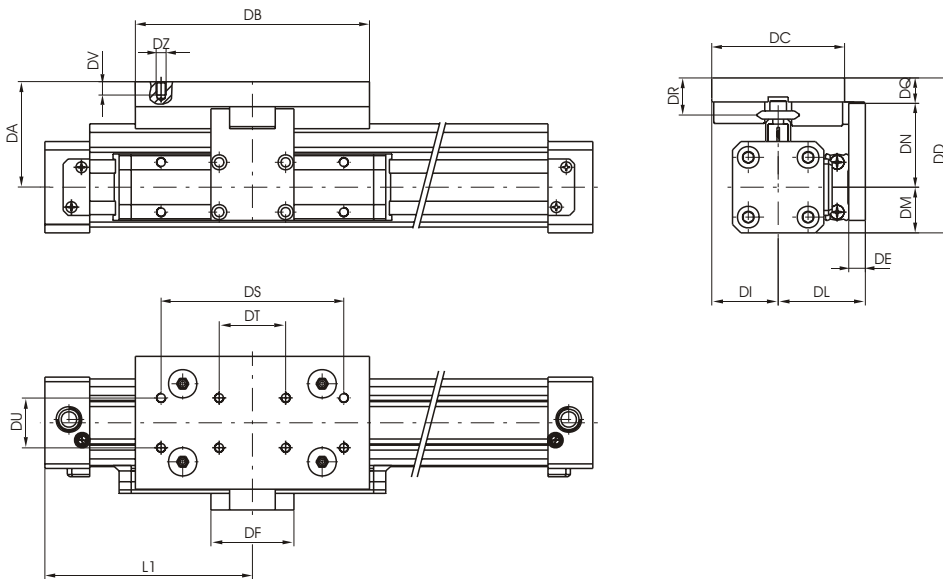

Bore	DA	DB	DC	DD	DE	DF	DI	DL	DM	DN	DQ	DR	DS	DT	DU	DV	DZ	L1	Weight guide	every 100 mm
25	65	120	65	85	8	40	32,5	44	20	45,5	19,5	29	80	30	23	8	M6	100	gr. 850	gr. 90
32	63	141	80	90,5	10	50	40	52,5	27,5	48,5	14,5	21,5	110	40	30	8	M5	125	gr. 950	gr. 90
40	68,5	141	80	101	10	50	40	57,5	32,5	54	14,5	21,5	110	40	30	8	M5	150	gr. 950	gr. 90

For cylinder weight refer to base version

Construction characteristics of linear control unit

Rod	carbon steel with hardness higher than 55-60 HRC
Bearing with shaft	shielded bearing with shaped ring
Carriage plate	anodized aluminium
Cover	acetal resin

Cylinder with sliding shoes guide
 (Ø 25 (1"), Ø 32 (1-1/4") and Ø 40 (1-5/8"))

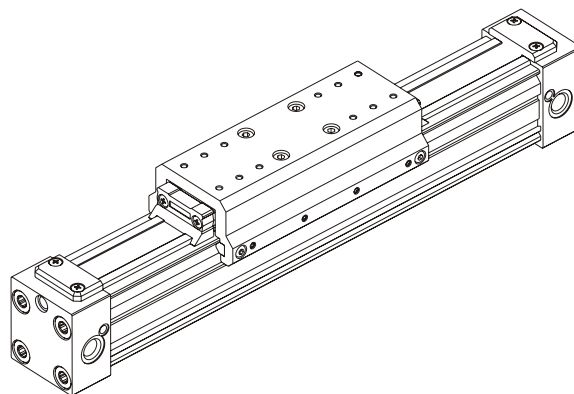

Ordering code

1605.Ø.corsa.01.MH Cylinder with sliding shoes guide

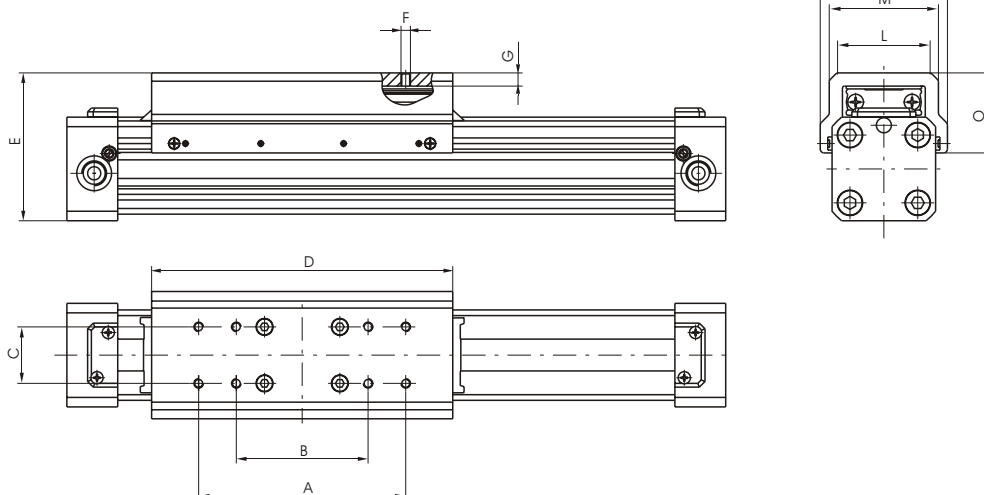

CYLINDER BORE	A	B	C	D	E	F	G	H	L	M	O	Weight gr.
Ø 25	80	55	23	130	64 ^{±1}	M4	6.5	57	36	42	32	235
Ø 32	110	70	30	160	78.5 ^{±1}	M5	7	68	50	58	42.5	445
Ø 40	110	70	30	202	88.5 ^{±1}	M5	7	77	52	60	45.5	595

For cylinders weight refer to base version

Ordering code

1600.Ø.05F Complete sliding shoes guide

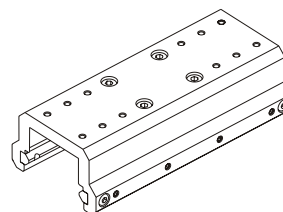

Construction Characteristics of Guide

Sliding shoes guide	reinforced carbon fiber nylon
Mounting plate	extruded anodized aluminium

Basic version cylinder

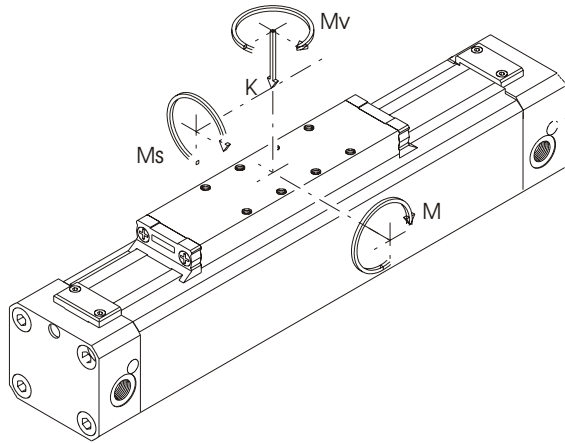

Operating end stroke decelerator diagram

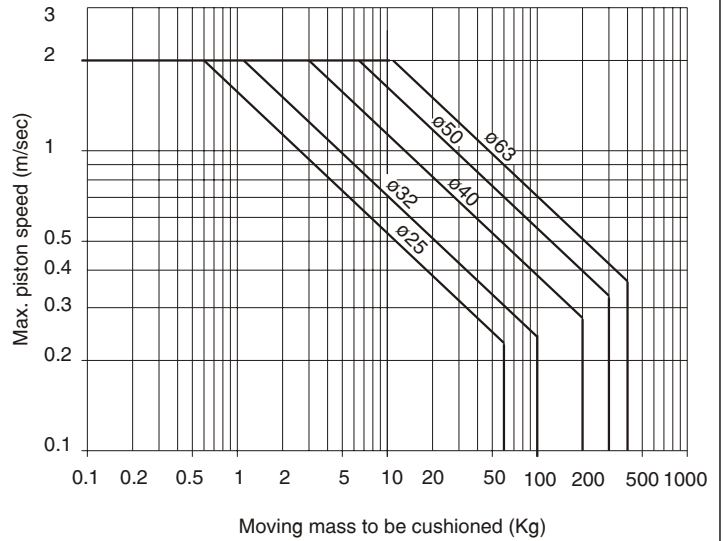

Recommended loads and moments in static conditions

CYLINDER BORE	DECELERATING STROKE (mm)	MAX. RECOMMENDED LOAD K (N)	MAX. RECOMMENDED BENDING MOMENT M (Nm)	MAX. RECOMMENDED CROSS MOMENT Ms (Nm)	MAX. RECOMMENDED TWISTING MOMENT Mv (Nm)
25	20	300	15	0,8	3
32	25	450	30	2,5	5
40	31	750	60	4,5	8
50	38	1200	115	7,5	15
63	49	1600	150	8,5	24

Calculation of permissible load (Kd) in dynamic conditions $K_d = K \cdot C_v$

Coefficient of velocity diagram

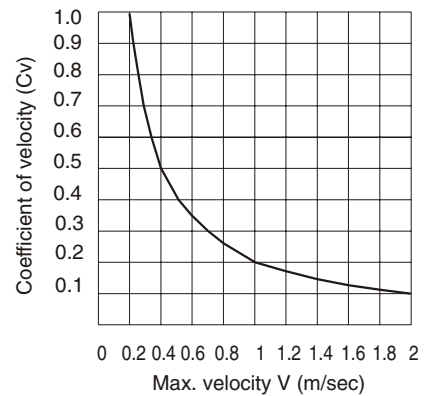

Loads under combined stressing conditions

It is important to take into consideration the following formula when there are a combination of forces with torque:

$$\left[\left(2 \times \frac{M_s}{M_{s \max}} \right) + \left(1.5 \times \frac{M_v}{M_{v \max}} \right) + \frac{M}{M_{\max}} + \frac{K}{K_{\max}} \right] \times \frac{100}{C_v} \leq 100$$

Cylinders with linear control unit Ø32 and Ø40

Max. suggested loads and moments

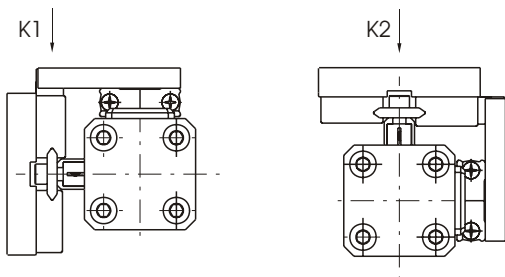
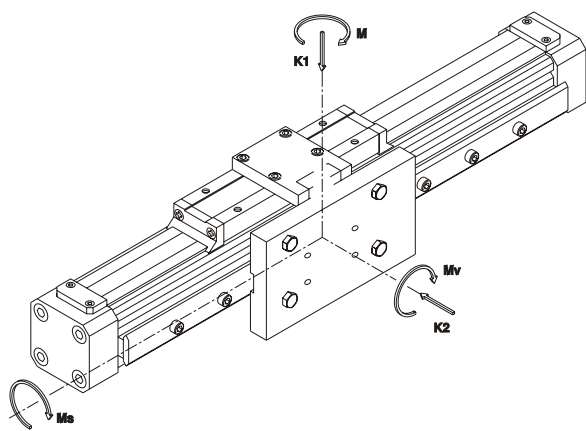

K1 (N)	K2 (N)	M (Nm)	Ms (Nm)	Mv (Nm)
960	960	40	12	40

Max. load (K1 o K2) depending on the distance LC between the supports

K1 K2

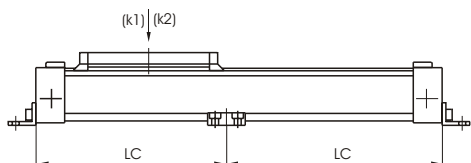
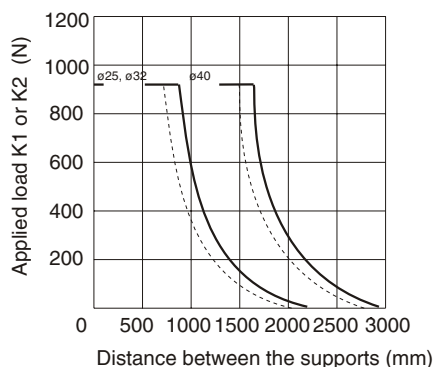

Real load (CE) under combined stressing conditions

It is important to take into consideration the following formula when there are a combination of forces with torque :

$$CE = [K1 + K2 + (24 \times M) + (80 \times Ms) + (24 \times Mv)] \leq 960$$

Nomograph load / life

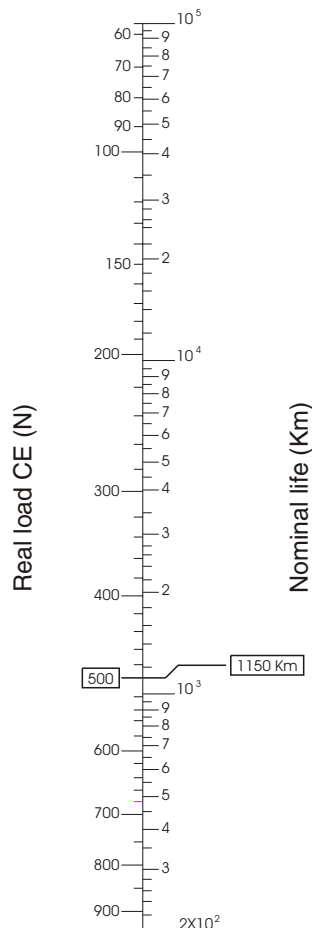

All data refers to a linear control unit properly lubricated with linear speed < di 1,5 m/s

Example to compute the life

Compute the linear control unit life with a load of 100 N applied 50 mm off its axle.

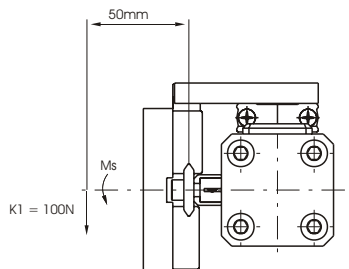

$$Ms = 0,05 \times 100 = 5 \text{ Nm}$$

$$K1 = 100 \text{ N}$$

How to compute the real load using the formula:

$$CE = [K1 + K2 + (24 \times M) + (80 \times Ms) + (24 \times Mv)]$$

$$CE = [100 + 0 + (24 \times 0) + (80 \times 5) + (24 \times 0)] = 500 \text{ N}$$

After having verified that the CE is lower than 960 N we realize that the life is 1150 Km from the nomograph.

Cylinder with sliding shoes guide $\varnothing 25$, $\varnothing 32$ and $\varnothing 40$

Max. suggested loads and moments

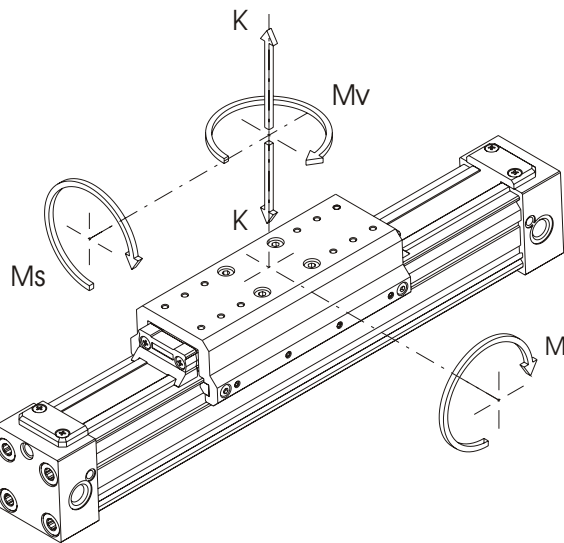

Recommended loads and moments in static conditions

CYLINDER BORE	MAX RECOMMENDED LOAD K (N)	MAX RECOMMENDED BENDING MOMENT M (Nm)	MAX RECOMMENDED CROSS MOMENT M_s (Nm)	MAX RECOMMENDED TWISTING MOMENT M_v (Nm)
$\varnothing 25$	300	20	1	4
$\varnothing 32$	450	35	3	6
$\varnothing 40$	750	70	5	9

Sensor brackets

Ordering code

1600.A

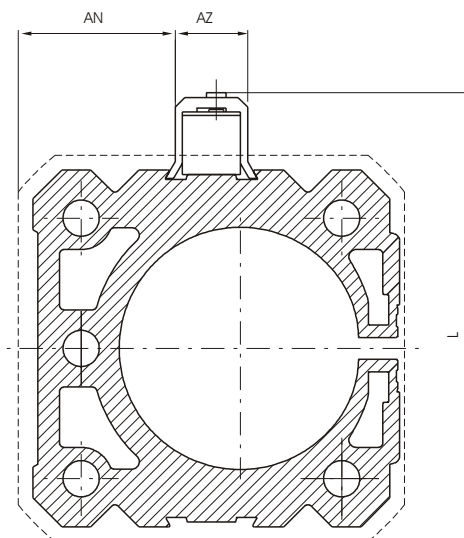

Bore	25	32	40	50	63
AN	12,5	20	25	32,5	40
AZ	15	15	15	15	15
L	55	68	79	94	110
Weight gr.	6	6	6	6	6

Sensors

For technical characteristics and ordering codes see page 8.0 and following.

Instruction on how to use the sensors propely

Particular attention must be paid not to exceed the working limits listed in the tables and that the sensor is never connected to the mains without a load connected in series; these are the only measures that if not observed can put the circuits out of order. In the case of direct current (D.C.) connection polarities must be respected, that is the brown wire to the positive load (+) and the blue to the negative (-). If these are inverted the sensor remains switched, the load connected and the led turned off. However, this would not damage the circuit.

For the "U" type sensors attention must be paid that the length of the cable doesn't exceed 8 meters, with tension above 100 V. In this case a serial resistance is addad to reduce the capacitive effects of the line.

As an example 1000 Ω per 100-130 V e 2000 Ω per 200-240 V.

Mounting foot brackets

Ordering code

1600.Ø.01F (1 piece)

**Bore
25 - 32**

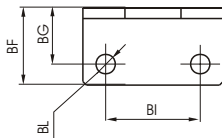
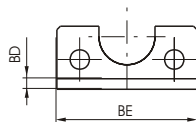
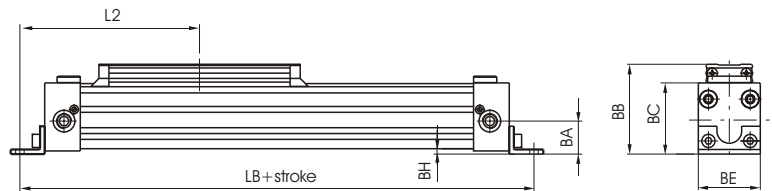

Bore	25	32	40	50	63
BA	21,5	28	32,5	41	49
BB	58	72,5	81,5	100	116
BC	46	57,5	66,5	82	97,5
BD	3	3	20	25	30
BE	40	55	65	80	95
BF	22	25	25	25	30
BG	16	18	12,5	12,5	15
BH	3,5	6	4,5	5	5
BI	27	36	30	40	48
BL	5,5	6,6	9	9	11
L2	116	143	162,5	187,5	230
LB	232	286	325	375	460
Weight gr.	30	45	65	110	190



**Bore
40 - 50 - 63**

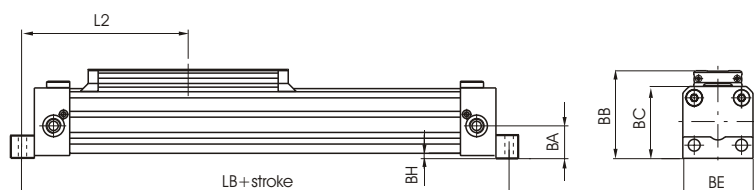
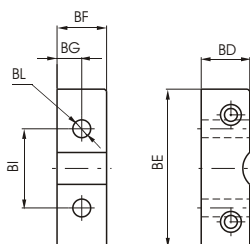



Intermediate support

Ordering code

1600.Ø.02F (1 piece)

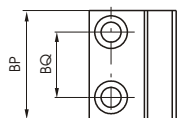
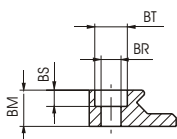

**Bore
25 - 32**

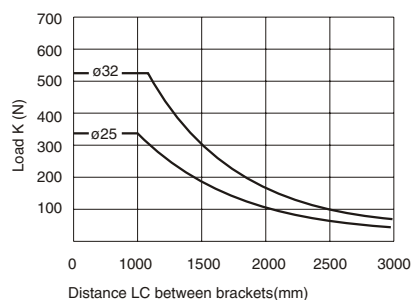
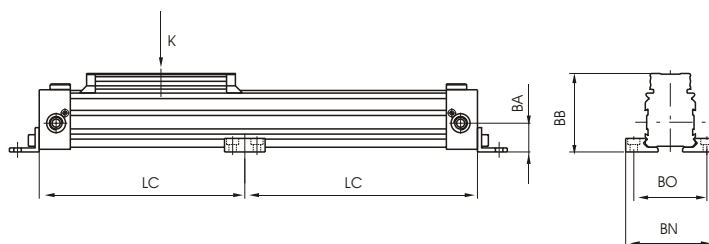

Bore	25	32	40	50	63
BA	21,5	28	32,5	41	49
BB	58	72,5	81,5	100	116
BM	10	18	18	25	30
BN	66	86	96	120	140
BO	54	70	80	100	120
BP	30	40	40	50	50
BQ	18	25	25	32	32
BR	5,5	6,6	6,6	9	9
BS	4,5	5,5	5,5	7,5	7,5
BT	9	11	11	15	15
Weight gr.	25	80	80	160	215

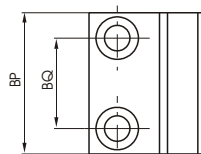
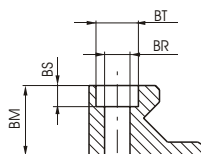

**Bore
40 - 50 - 63**

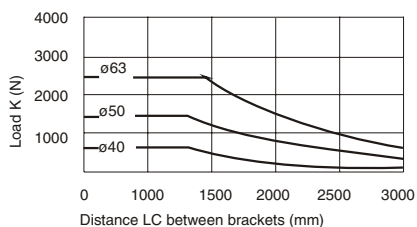
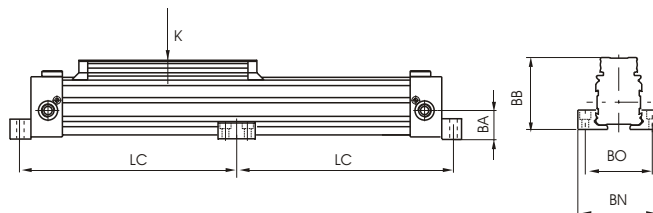



Oscillating hinge

Ordering code

1600.Ø.03F

**Bore
25 - 32 - 40**

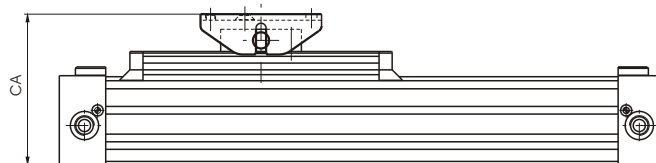
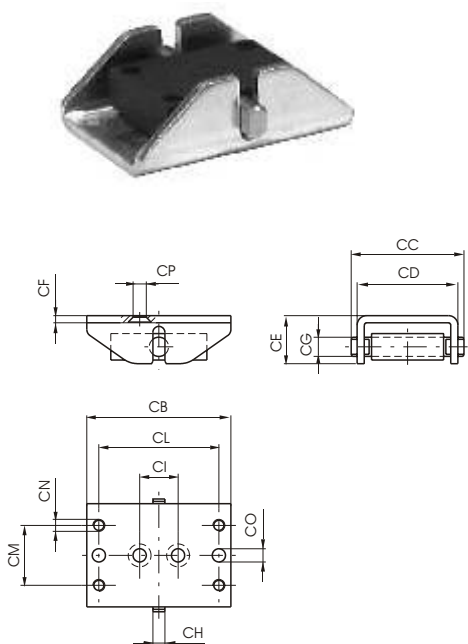

Bore	25	32	40	50	63
CA (± 5.5)	76	99,5	108,5	135,5	151
CB	60	100	100	120	120
CC	47	64	64	92	92
CD (± 5)	42	56	56	80	80
CE	20	30	30	42	42
CF	3	4	4	6	6
CG	8	12	12	16	16
CH	5	8	8	10	10
CI	16	40	40	65	65
CL	50	80	80	100	100
CM	25	30	30	47	47
CN	M 5	M 6	M 6	M 8	M 8
CO	5,5	6,5	6,5	9	9
CP	5,5	7	7	-	-
Weight gr.	130	380	380	990	990



**Bore
50 - 63**

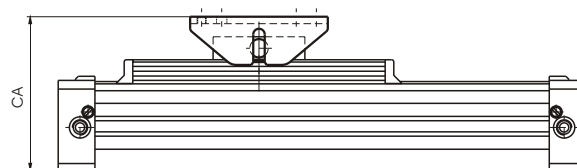
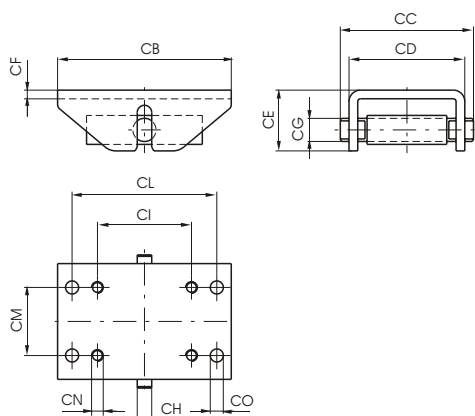

General

The cable cylinders work in a linear translation systems, they are very compact and are to be used where a normal cylinder with a rigid rod is too cumbersome. The main characteristic of the cable cylinders is the absence of the rod which, in coming out of the end plate at the end of the stroke, doubles the total overall dimension of the cylinder. In the case of the cable cylinder, the rod is replaced by a metal rilsan-coated cable. It is connected to the piston and coming at the maximum point of stroke never exceeds the overall dimensions of the cylinder.

The cable are connected to the bracket with clamps which serve also to regulate the tension. Because of the construction characteristics of this type of cylinder it must be used with much attention. The cable is capable of supporting large stress due to heavy load and high speed. Unfortunately, we cannot give definitive limits of use if not in presence of masses of a few kilograms to be translated (7 ÷ 10 for 16 and 20 ÷ 25 for Ø 25) with speed inversely proportional to the entity of the same load (max 0,5 m/sec). This is done in a way that the load always has a mechanical stop at the end of the stroke. The magnetic piston version legthens the overall dimensions by 50 mm; the serie 1200 microcylinders sensors are used along with the clips of that series.

Construction characteristic

End plates	anodized black aluminium	Piston seal	NBR 80 Shore (at lip)
Barrel	anodized aluminium	Cable seal	polyurethane mixture
Piston	aluminium	Bracket	steel
Cable	steel	Cable clamps	brass
Cable covering	rilsan	Pulleys	aluminium with ball bearing

Technical characteristics

Fluid: filtered and lubricating air | Max. pressure: 6 bar | Min. and max. temperature: -5°C ÷ +70°C | Max speed: 0,5 m/sec.

"Attention: We recommend using dry air if the working temperature is lower than 0°C"

	A	B	C	D
Standard	111	132	86	124
Magnetic	161	182	136	174

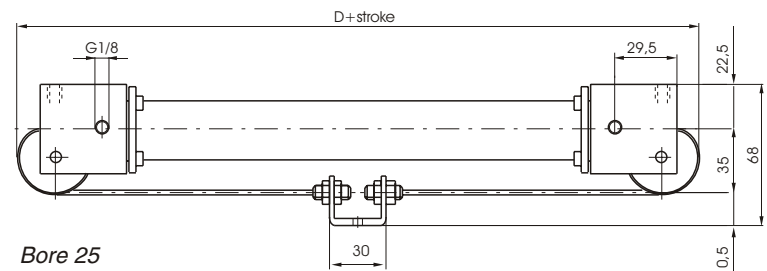
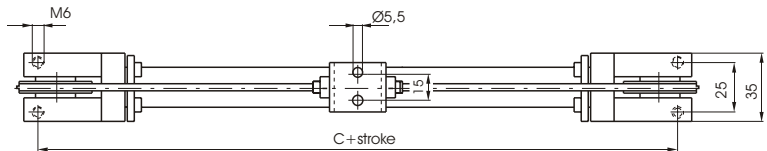
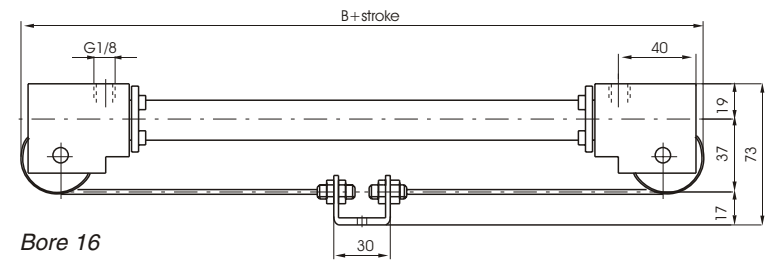
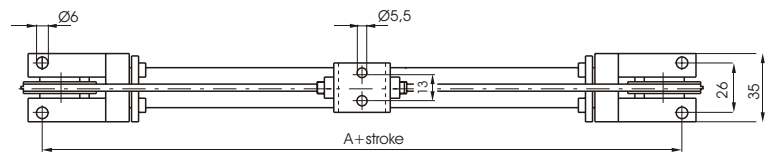

Ordering code
1601.Ø.stroke
1601.Ø.stroke.M
Version with magnetic piston

Maintenance

The cable is obviously the part most subject to breakage. The cylinder can be disassembled for replacement of the cable which is supplied already complete with threaded bushings to be screwed on to the piston. Once the wear of the barrel and seals has been checked, the cylinders can be reassembled by screwing on the end plates. Next, the ends of the cable are attached to the bracket by way of clamps and the tension regulated. The tension is correct when the cable is not cambered.