



## Pressure booster

	Page
General	5.1
Pressure boosters $\varnothing$ 40	5.2
Pressure boosters $\varnothing$ 40 c/w air pressure regulator	5.3
Pressure booster $\varnothing$ 63	5.4
Pressure booster $\varnothing$ 63 c/w air pressure regulator	5.5
Pressure booster $\varnothing$ 100	5.6
Pressure booster $\varnothing$ 100 c/w air pressure regulator	5.7
Accessories	5.8



**GENERAL**

It is not unusual that, during some applications the thrust generated by a pneumatic cylinder is not sufficient for the specific purpose it has been designed for. In order to get over the problem, the working pressure may be increased to a maximum line pressure which normally is 6 - 7 bar; alternatively the problem is solved by an higher bore cylinder that suits the machine. Three size pressure boosters, with pressure ratio of 1 - 2, have been designed to avoid these problems. This device is utilizing the compressed air of the circuit where it is installed.

**CONSTRUCTION AND WORKING CHARACTERISTICS**

The working method is based on the pump effect of the four chambers cylinder as shown in fig. 1. Two chambers are alternatively compressing the air in the boost one, while the fourth one is discharging. By means of an internal circuit, the pressure booster keeps on pumping air till the down stream pressure reaches a value double the inlet pressure. In these circumstances there is a balance condition. When the down stream pressure decreases, the pressure booster starts again its alternating cycle till a new balance condition is restored. The pressure booster can be furnished complete with pressure regulator installed on the inlet port for getting an accurate outlet pressure value. A wall mounting plate is also available.

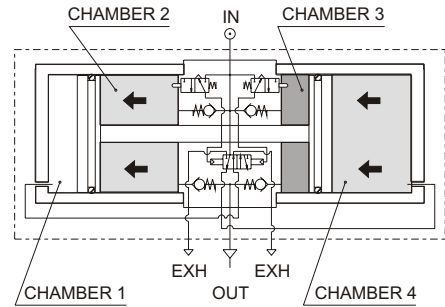

**INSTRUCTIONS FOR INSTALLATION AND USE**

Do not exceed the suggested temperature and pressure values. It is advisable to install a small air tank after the pressure booster to avoid pressure pulsation effects. Discharge the down stream circuit before any maintenance operation as the inner circuit of the booster does not allow the down stream line discharge even if the inlet pressure drops down.

**MAINTENANCE**

Pressure booster has an average life of about 20 millions of valve cycles, depending on working conditions (every back stroke corresponds to one valve cycles). A proper lubrication and filtration of air improve the life of pressure booster parts. It is advisable to protect the exhaust ports in environment. Replaceable spare seal kits are available.

**HOW TO CALCULATE THE REQUIRED TIME OF PRESSURE BOOSTER TO INCREASE THE AIR PRESSURE IN A TANK WHOSE CAPACITY IS KNOWN.**

- Operating Data :
- P1 = Inlet pressure
  - P2' = Tank initial pressure
  - P2'' = Tank final pressure
  - V = Tank volume

**PROCEDURE :**

- 1) Calculate the ratio K' between the initial pressure of the tank and the inlet pressure of the booster ( P2' / P1 ).
- 2) Calculate the ratio K'' between the final pressure of the tank and the inlet pressure of the booster ( P2'' / P1 ).
- 3) Locate the intersection point between the ratio K' and the curve on filling time diagram related to the specific booster. Trace a vertical line from the above point and read the correspondent time T' ( the example shows the ratio K = 0.8 and correspondent time of about 4.2 seconds ).
- 4) Repeat same procedure also for ratio K'' to get time T''.

5) Use the following formula  $T = \frac{V}{10} \cdot (T'' - T')$

to obtain the total time required to move the pressure P2' to P2'' of tank volume V.

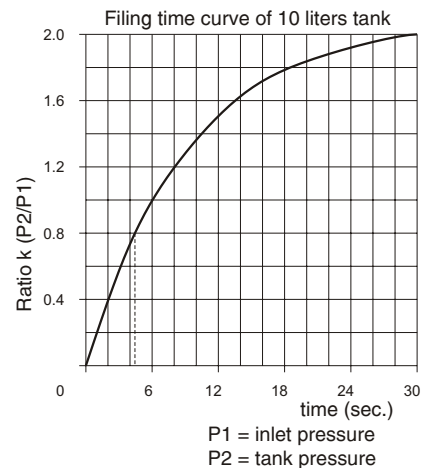

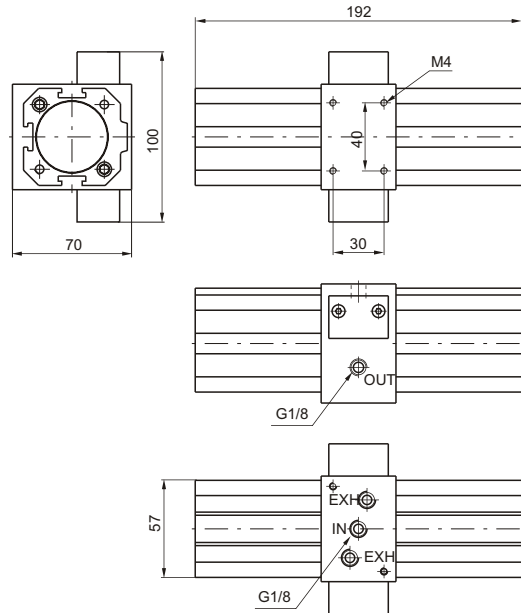

### Construction and working characteristics

- Self operating pressure booster with pressure ratio of 1:2.
- Automatic functioning: to operate the booster just connect it to compressed air line.
- Body made with light alloy.
- Barrel made of extruded and anodized aluminium.
- Downstream circuit pressure is kept under pressure even in absence of inlet pressure.

### Technical characteristics

Connections	G 1/8"
Working pressure range	2-10 bar
Max. ambient temperature	50°C
Nominal orifice diameter	$\varnothing$ 5 mm
Weight	gr 1500
Assembling position	Any
Max. fittings torque	15 Nm

Ordering code

**1740.50**

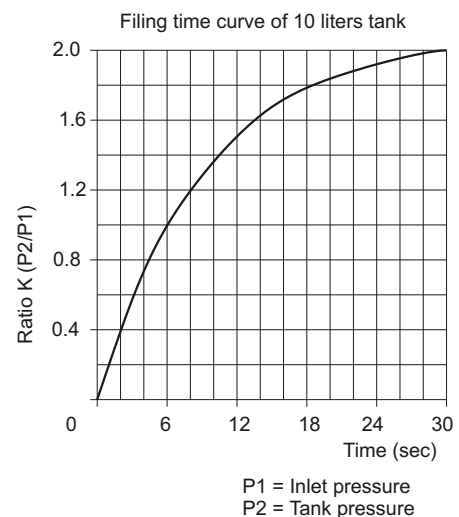
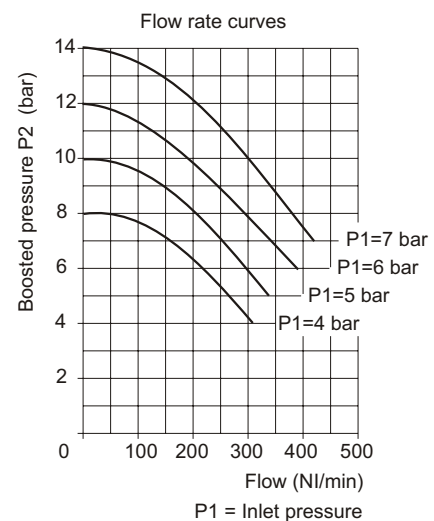

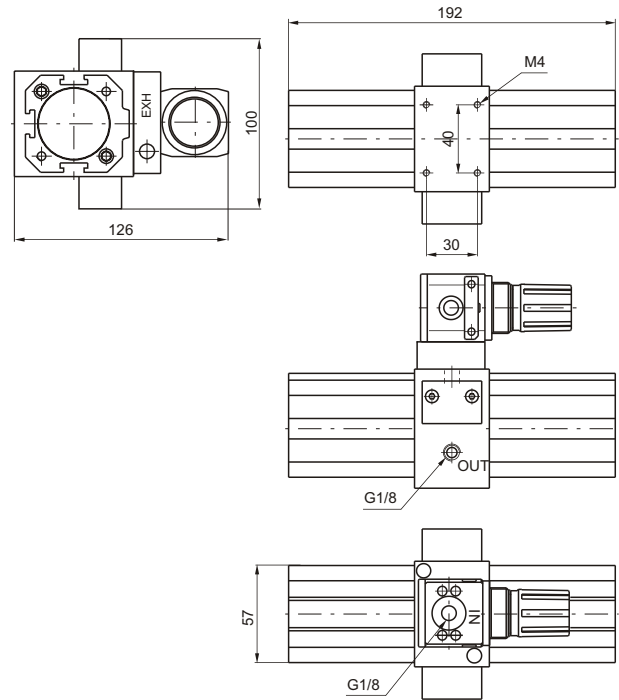

### Construction and working characteristics

- Self operating pressure booster with pressure ratio of 1:2.
- Automatic functioning: to operate the booster just connect it to compressed air line.
- Body made with light alloy.
- Barrel made of extruded and anodized aluminium.
- Downstream circuit pressure is kept under pressure even in absence of inlet pressure.
- Possibility to adjust the inlet pressure and consequently the boosted pressure.

### Technical characteristics

Connections	G 1/8"
Working pressure range	2-10 bar
Max. ambient temperature	50°C
Nominal orifice diameter	$\varnothing$ 5 mm
Weight	gr 1600
Assembling position	Any
Max. fittings torque	15 Nm

Ordering code

**1740.50.R**

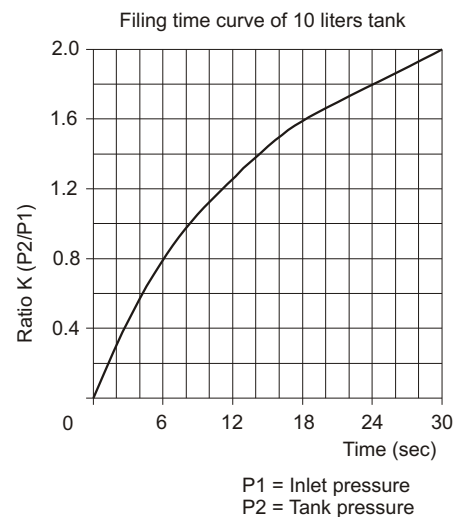
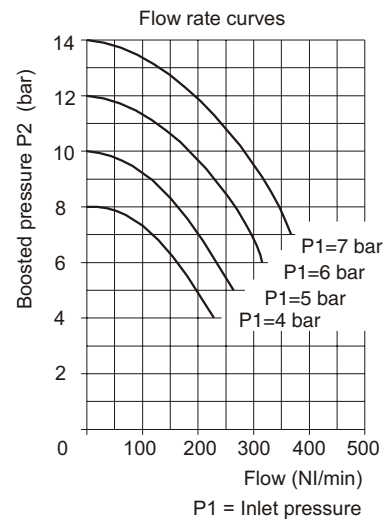

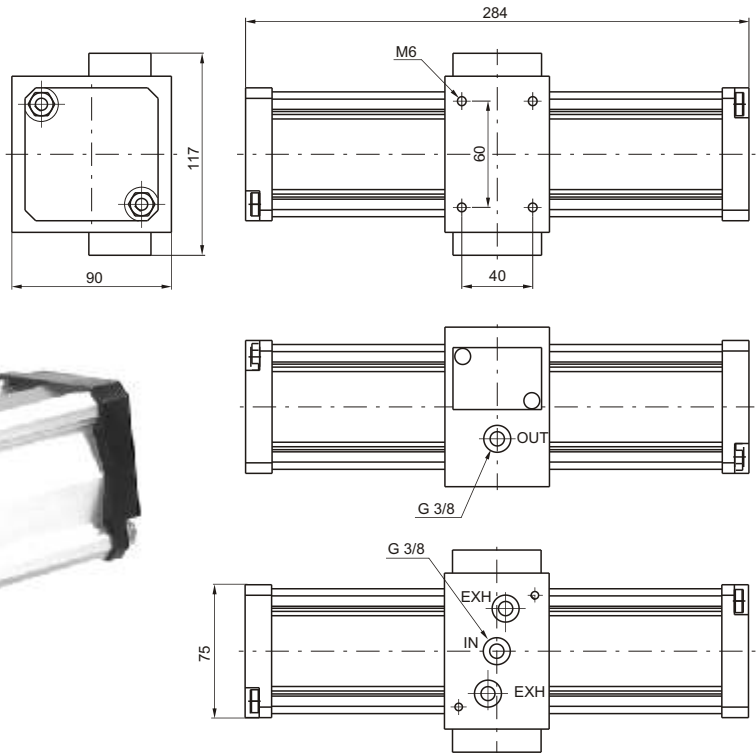

### Construction and working characteristics

- Self operating pressure booster with pressure ratio of 1:2.
- Automatic functioning: to operate the booster just connect it to compressed air line.
- Body made with light alloy.
- Barrel made of extruded and anodized aluminium.
- Downstream circuit pressure is kept under pressure even in absence of inlet pressure.

### Technical characteristics

Connections	G 3/8"
Working pressure range	2-8 bar
Max. ambient temperature	50°C
Nominal orifice diameter	$\varnothing$ 7 mm
Weight	gr 3000
Assembling position	Any
Max. fittings torque	15 Nm

Ordering code

**1763.80**

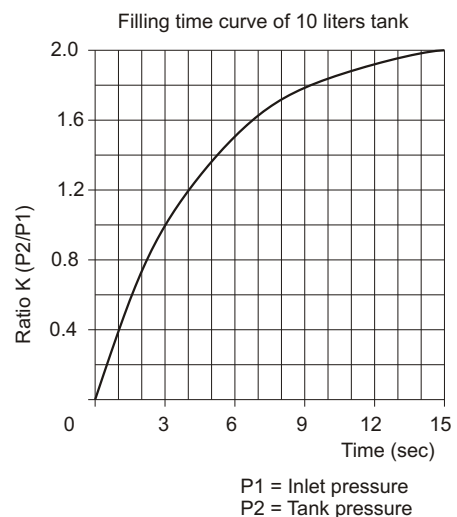
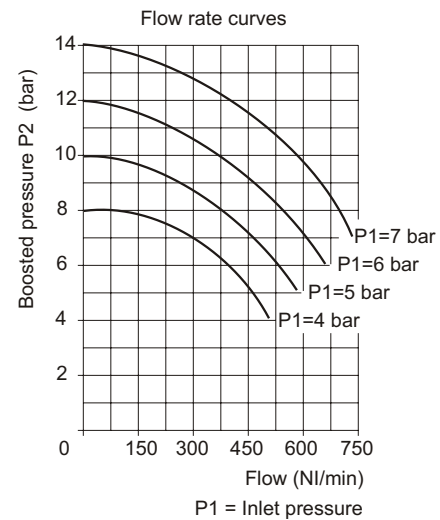

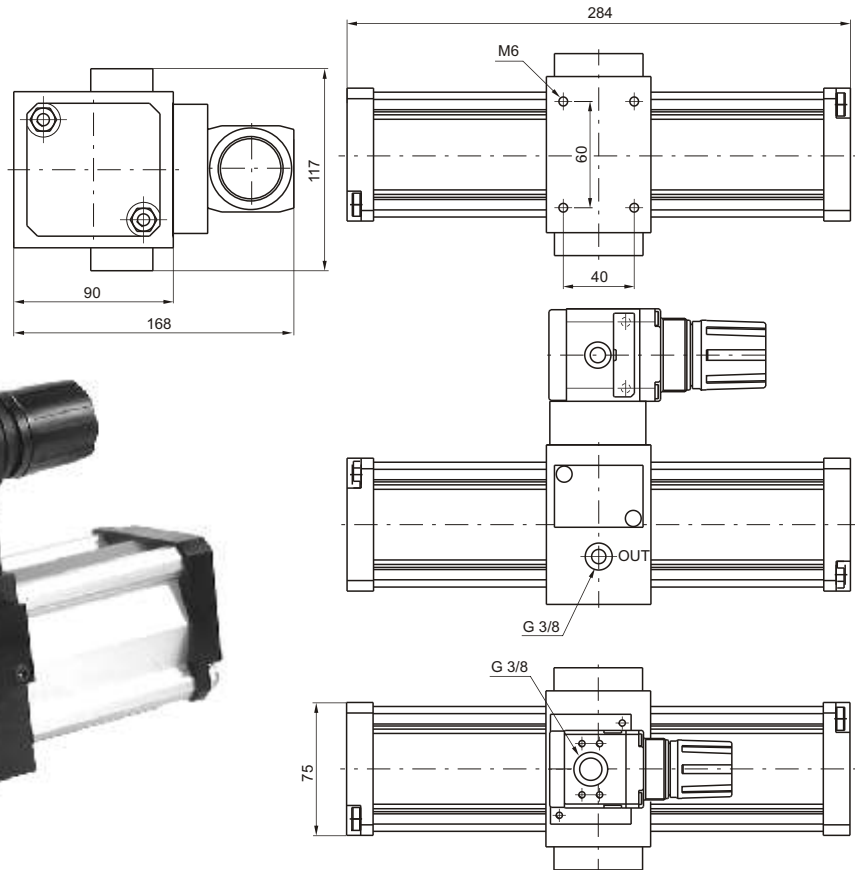

**Construction and working characteristics**

- Self operating pressure booster with pressure ratio of 1:2.
- Automatic functioning: to operate the booster just connect it to compressed air line.
- Body made with light alloy.
- Barrel made of extruded and anodized aluminium.
- Downstream circuit pressure is kept under pressure even in absence of inlet pressure.
- Possibility to adjust the inlet pressure and consequently the boosted pressure.

**Technical characteristics**

Connections	G 3/8"
Working pressure range	2-8 bar
Max. ambient temperature	50°C
Nominal orifice diameter	$\varnothing$ 7 mm
Weight	gr 3200
Assembling position	Any
Max. fittings torque	15 Nm

Ordering code

**1763.80.R**

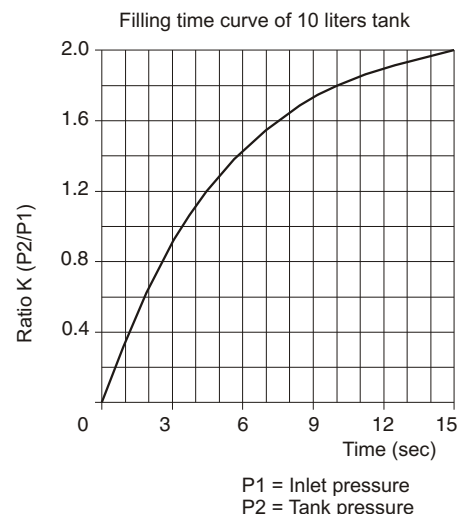
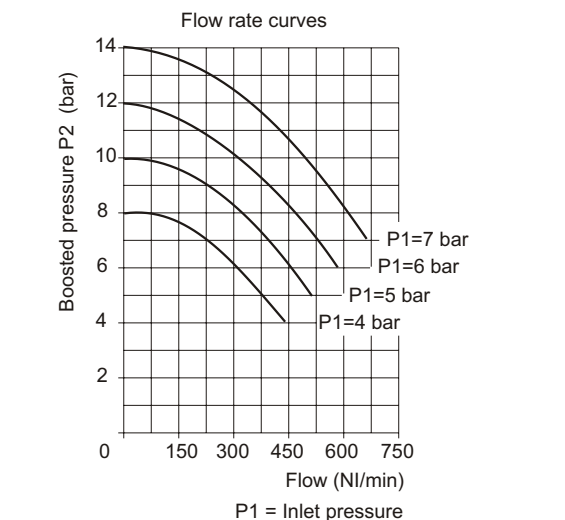

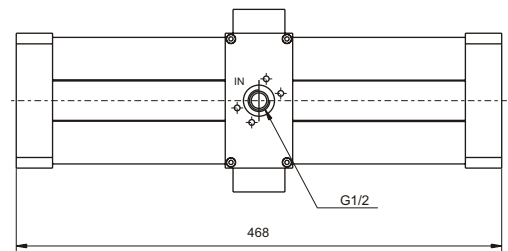
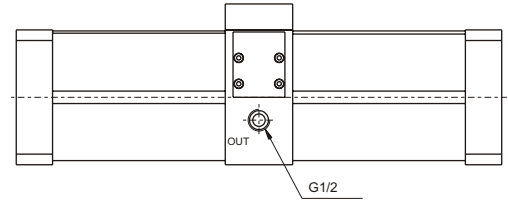
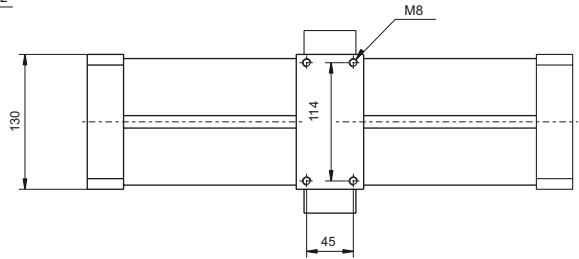
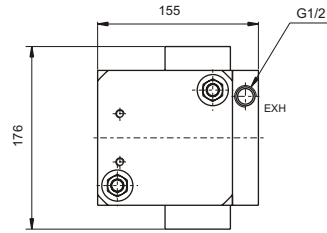

### Construction and working characteristics

- Self operating pressure booster with pressure ratio of 1:2.
- Automatic functioning: to operate the booster just connect it to compressed air line.
- Body made with light alloy.
- Barrel made of extruded and anodized aluminium.
- Downstream circuit pressure is kept under pressure even in absence of inlet pressure.

### Technical characteristics

Connections	G 1/2"
Working pressure range	2-8 bar
Max. ambient temperature	50°C
Nominal orifice diameter	$\varnothing$ 12 mm
Weight	gr 12000
Assembling position	Any
Max. fittings torque	40 Nm

Ordering code

**17100.125**

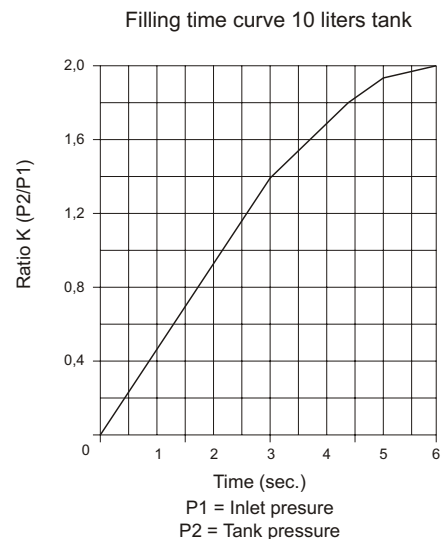
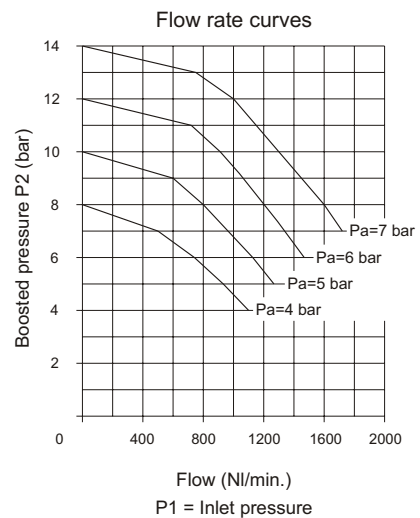

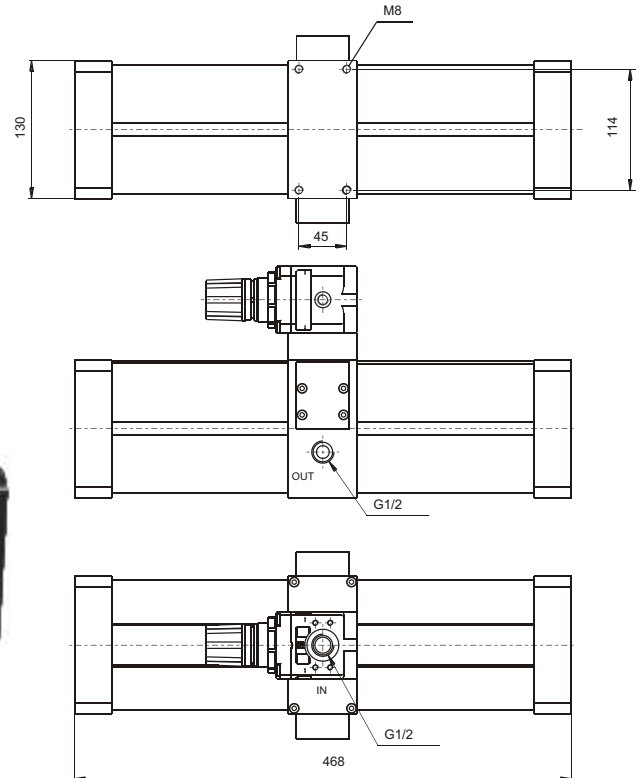
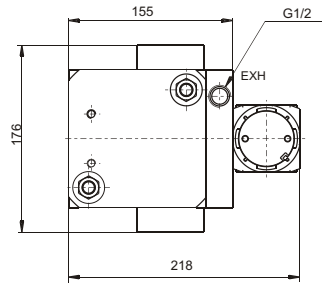
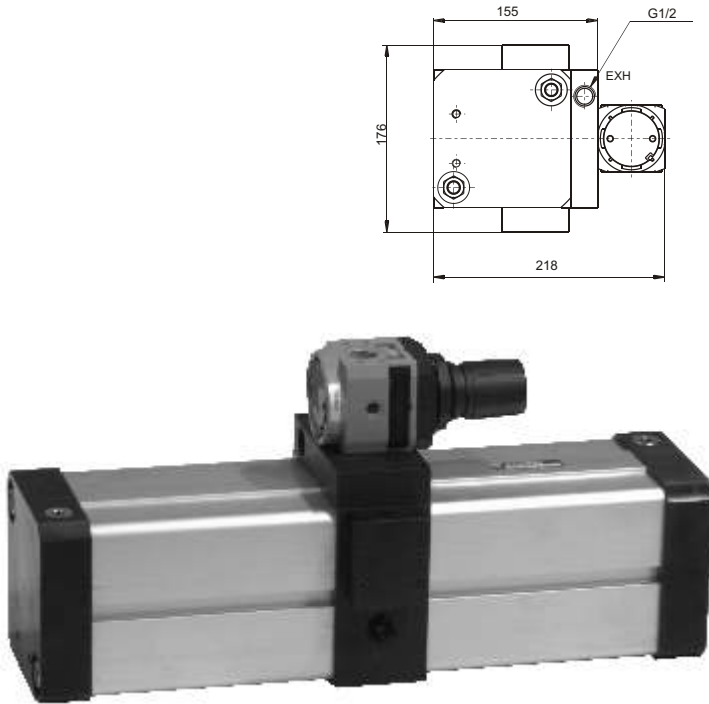

### Construction and working characteristics

- Self operating pressure booster with pressure ratio of 1:2.
- Automatic functioning: to operate the booster just connect it to compressed air line.
- Body made with light alloy.
- Barrel made of extruded and anodized aluminium.
- Downstream circuit pressure is kept under pressure even in absence of inlet pressure.
- Possibility to adjust the inlet pressure and consequently the boosted pressure.

### Technical characteristics

Connections	G 1/2"
Working pressure range	2-8 bar
Max. ambient temperature	50°C
Nominal orifice diameter	$\varnothing$ 12 mm
Weight	gr 12600
Assembling position	Any
Max. fittings torque	40 Nm

Ordering code

**17100.125.R**

Flow rate curves

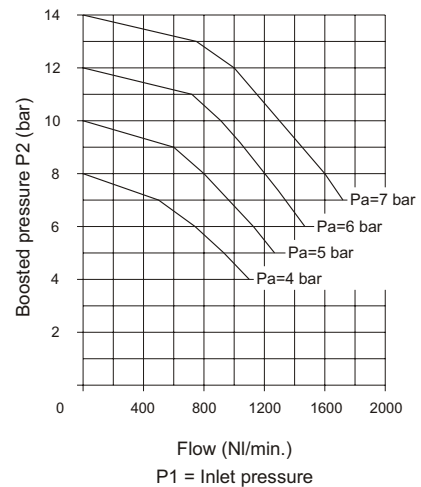

Filling time curve 10 liters tank

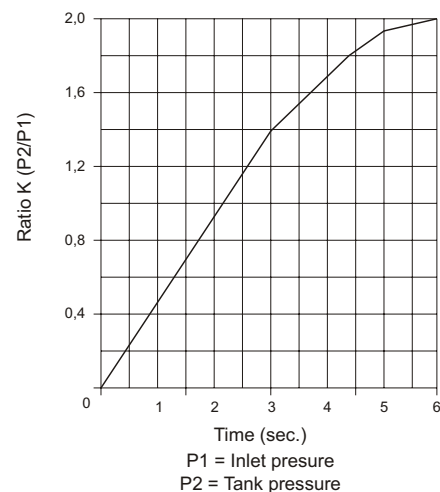

**Base complete with pressure reducer**

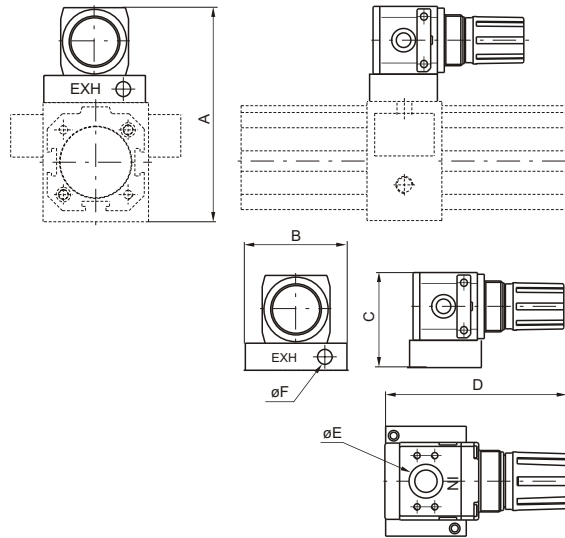

Ordering code

**17 . BR**

40 = Base complete with pressure reducer for ø 40 booster  
63 = Base complete with pressure reducer for ø 63 booster  
100 = Mount directly the pressure reducer Code 17302B.C

DIMENSIONS						
CODE	A	B	C	D	E	F
1740.BR	126	60	56	91	G1/8"	G1/8"
1763.BR	168	75	78	124	G3/8"	G3/8"

**Booster mounting plate**

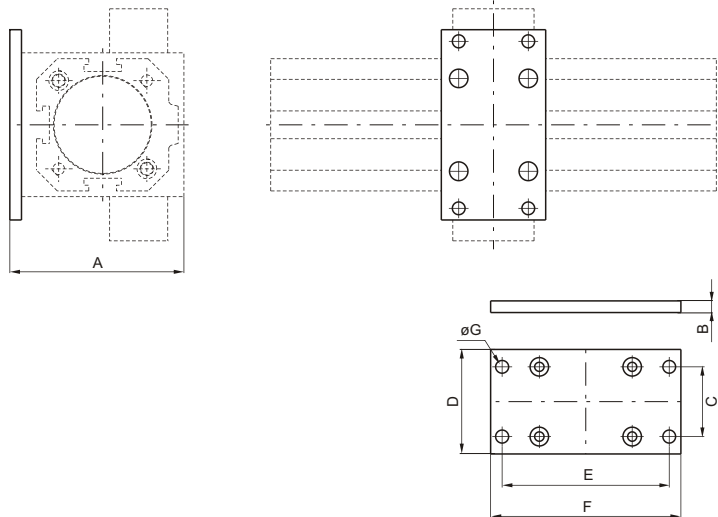

Ordering code

**17 . 02**

40 = Mounting plate for ø 40 booster  
63 = Mounting plate for ø 63 booster  
100 = Use short foot bracket code 1320.50.05/1F

DIMENSIONS							
CODE	A	B	C	D	E	F	F
1740.02	75	5	30	45	72	82	5.5
1763.02	105	15	53	70	98	110	M8