



## Size 3

	Page
General	3.1
Assembling	3.2
Filter	3.3
Coalescing filter	3.4
Pressure regulator	3.5
Pressure regulator including manometer	3.6
Lubricator	3.7
Filter - Pressure regulator	3.8
Progressive start-up valve	3.9
Shut-off valve	3.10
Service unit combination, 2 components	3.11 - 3.12
Service unit combination, 3 components	3.13 - 3.14
High sensitive air pressure regulator with high flow rate relieving	3.15
Filter G 3/4"	3.16
Coalescing filter G 3/4"	3.17
Pressure regulator G 3/4"	3.18
Lubricator G 3/4"	3.19
Filter - pressure regulator G 3/4"	3.20
Service unit combination, 2 components G 3/4"	3.21 - 3.22
Service Unit combination, 3 components G 3/4"	3.23 - 3.24
Accessories	3.25 - 3.26
Spare parts	3.27 - 3.30



## Construction and working characteristics

The modular air service units groups of the size 3, as the ones of size 1 and 2, allow a wide selection of combinations.

The threaded connections are machined directly on the valve body made with light alloy, so that each components can be used individually.

They can be wall mounted with head-guard screws masked by covers.

The bowls are made of transparent technopolymer, always supplied with shock resistant technopolymer protection, allowing the moisture and oil level control from any angle.

The filter can be equipped with manual or semiautomatic water drain valve; furthermore it's possible to install the automatic draining device inside the bowl.

The pressure regulator handle is lockable in the desired position.

The lubricator oil flow is adjustable with proper handle and it is visibly checked through the sight dome.

The shut-off valve can be equipped with pad-lock to prevent accidents or damages due to unauthorized operation.

The progressive start-up valve, pneumatically or electropneumatically controlled, allows air supply to the circuit progressively and with adjustable time.

Some accessories like the wall fixing bracket, pressure gauges with different scales and diameters, air intake block that assembled between the elements allows to get in the system filtered or filtered non-lubricated air, are completing the range.

## Instruction for installation and operation

Pay attention to install a group or a single component with air flow direction according to the arrows and to the following sequence: filter, pressure regulator, lubricator and with bowls downwards. It's possible to fix the group to the wall by removing the covers, which can be installed again for covering the screw after fixing.

Do not exceed the recommended torque while assembling the connectors.

Do not exceed the recommended air pressure and temperature limits.

The moisture should not exceed the level marked on the bowl and it can be drawn off and carried away by a flexible tube of  $\varnothing 6/4$  directly connected to the discharge valve handle.

The pressure should be set from minimum to maximum, rotating the adjusting handle clockwise.

As lubricant, we suggest to use oil class FD22 or HG32. Verify that the lubricator is not fed with a flow lower than the minimum operational.

To set the oil flow rotate the proper adjusting handle in order to get one drop of oil every 300-600 liters of air.

The oil flow will be kept automatically and proportionally to the air flow.

The oil can be refilled by mean of proper plug or directly into the bowl after having de-pressurized the system. Do not exceed the maximum level indicated on the bowl.

For opening the shut-off valve push and rotate clockwise the operating handle. For closing it and consequently discharging the down stream line, rotate the handle counter-clockwise.

## Maintenance

Clean the bowls with water and detergent. Do not use alcohol.

The filter element made with HPDE is reusable by blowing and cleaning it with proper detergent. For replacing or cleaning it, remove the bowl and unscrew the baffle spins.

Replace the pressure regulator diaphragm whenever the operation is not correct or there is a continuous air leaking through the relieving (over pressure discharge); reinstall the adjusting mechanism support locking it with about 8 Nm torque.

In case it is necessary to replace the lubricator transparent dome, tight it at 5 Nm torque

### Assembling

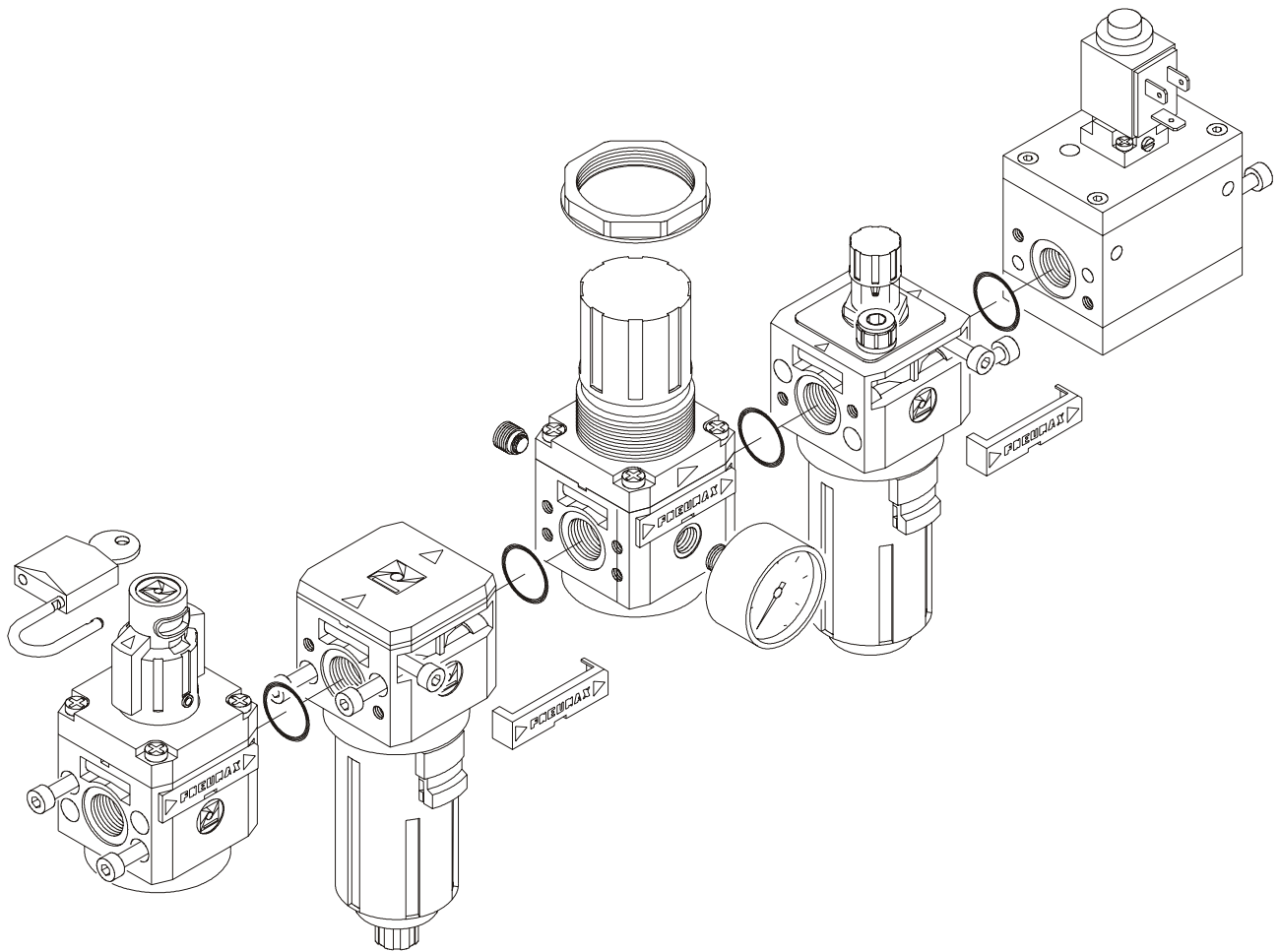

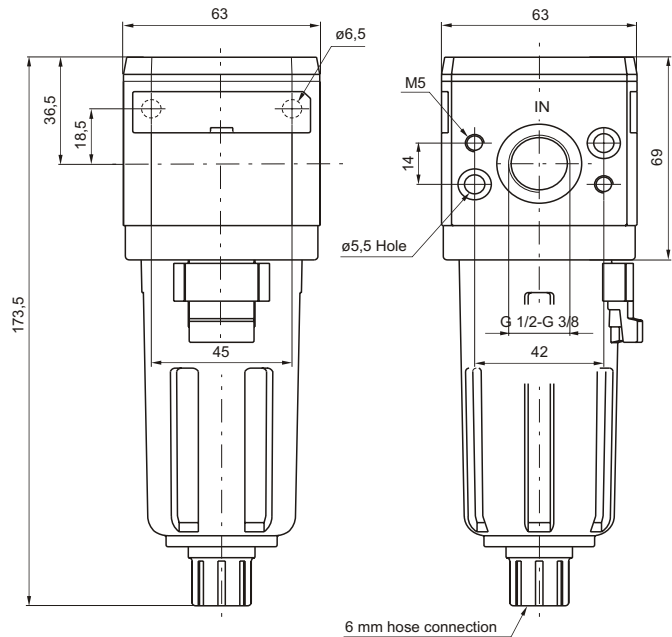

### Construction and working characteristics

- Body made with light alloy.
- Wall mounting possibility with M6 screws protected by covers.
- Double filtering action: by air centrifuging and by replaceable and reusable HDPE porous filter element.
- Transparent technopolymer bowl with shock resistant technopolymer protection connected to the body with bayonet cap and safety button.
- Manual and semi-automatic water drain valve; in the semi-automatic version the drainage happens when there is no pressure or by pushing the valve up-wards.
- Possibility to see the water level on 360°.
- Automatic water drainage bowl available on request.

### Technical characteristics

Connections	G 3/8" - G 1/2"
Max. inlet pressure	13 bar - 1,3 MPa
Max. ambient temperature (at 10 bar)	50°C
Weight	gr. 405
Filter pore size	5µ
	20µ
	50µ
Bowl capacity	42 cm <sup>3</sup>
Assembly position	Vertical
Wall fixing screws	M6
Max. fitting torque	40 Nm

Flow rate curves

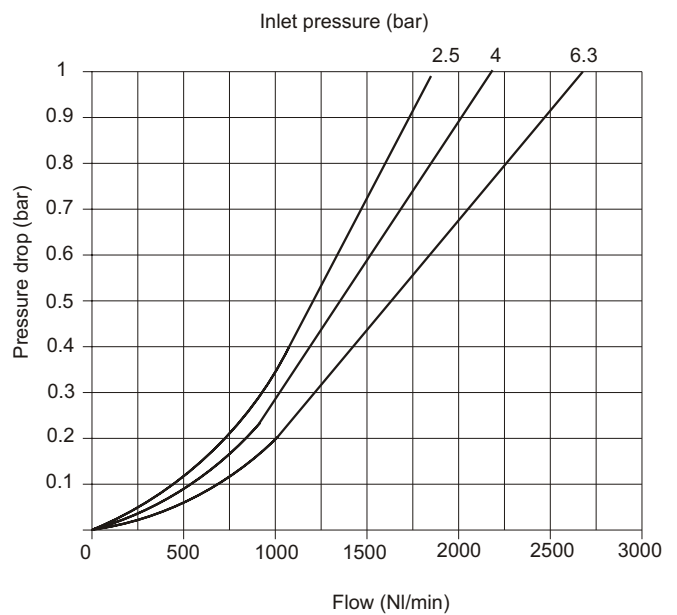

### Ordering code

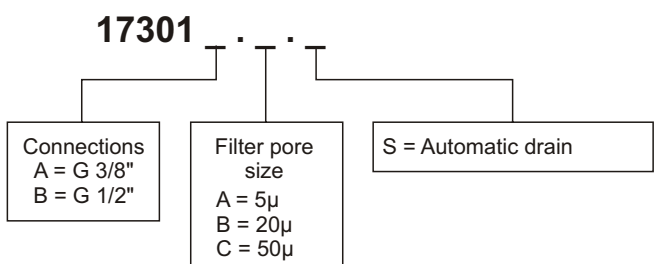

Example: **17301A.B**  
Filter size 3 with G 3/8" connections and filter pore size 20µ.

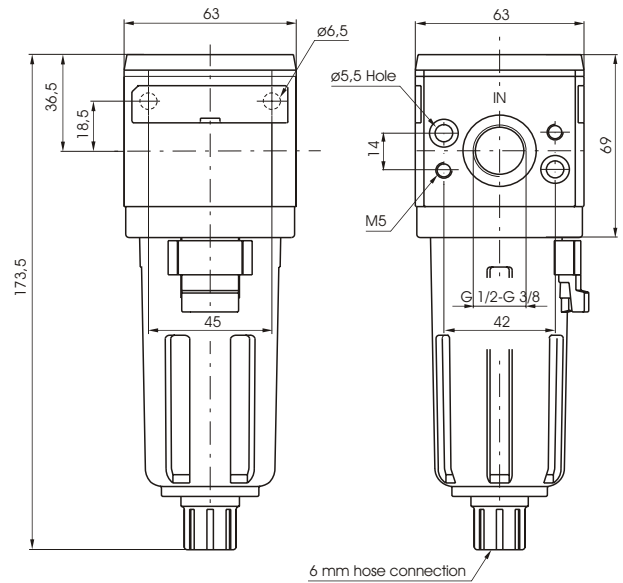

### Construction and working characteristics

- Coalescing filter element remove 0,1 $\mu$  particles equivalent to 99,97%.
- Body made with light alloy.
- Wall mounting possibility with M6 screws protected by covers.
- Transparent technopolymer bowl with shock resistant technopolymer protection connected to the body with bayonet cap and safety button.
- Manual and semi-automatic water drain valve; in the semi-automatic version the drainage happens when there is no pressure or by pushing the valve up-wards.
- Possibility to see the water level on 360° also with bowl protection assembled.
- Automatic water drainage bowl available on request.

### Technical characteristics

Connections	G 3/8" - G 1/2"
Max. inlet pressure	13 bar - 1,3 MPa
Max. ambient temperature (at 10 bar)	50°C
Weight	gr. 405
Filter efficiency with 0,1 $\mu$ particle	99,97%
Bowl capacity	42 cm <sup>3</sup>
Assembly position	Vertical
Wall fixing screws	M6
Max. fitting torque	40 Nm

Flow rate curves  
Inlet pressure (bar)

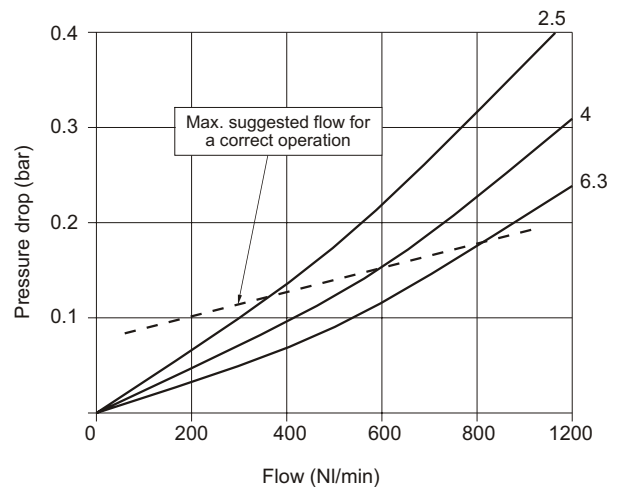

### Ordering code

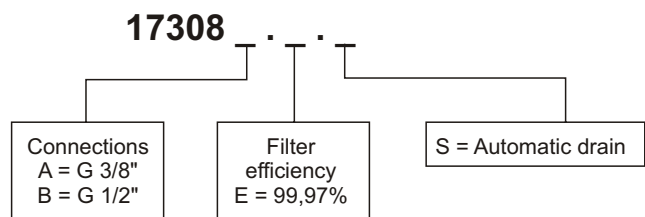

Example: **17308A.E**  
Coalescing filter size 3 with G 3/8" connections and filter efficiency of 99,97%.

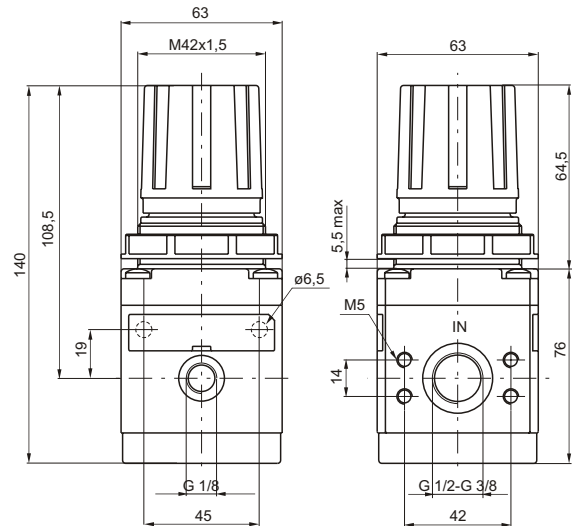

### Construction and working characteristics

- Diaphragm pressure regulator with relieving.
- Balanced poppet.
- Lockable handle by simply pressing it downwards in the desired position.
- Body made with light alloy.
- Wall mounting possibility with M6 screws protected by covers.
- Two pressure gauge connections with plug complete of seal.
- Panel mounting bracket.

### Technical characteristics

Connections	G 3/8" - G 1/2"
Max. inlet pressure	13 bar - 1,3 MPa
Max. ambient temperature	50°C
Pressure gauge connections	G 1/8"
Weight	gr. 550
Pressure range	0 - 2 bar
	0 - 4 bar
	0 - 8 bar
	0 - 12 bar
Assembly position	Any
Wall fixing screws	M6
Max. fitting torque	40 Nm

### Flow rate curves

Inlet pressure (7 bar)

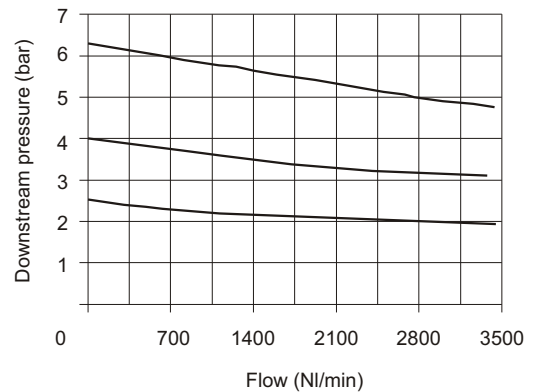

### Adjustment characteristics

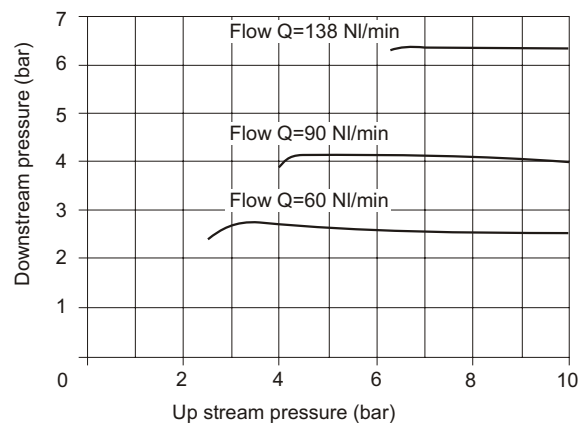

### Ordering code

**17302**

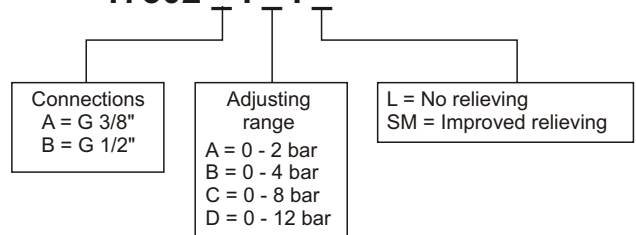

Example: **17302A.C**

Pressure regulator with G 3/8" connections, adjusting range 0 - 8 bar with relieving.

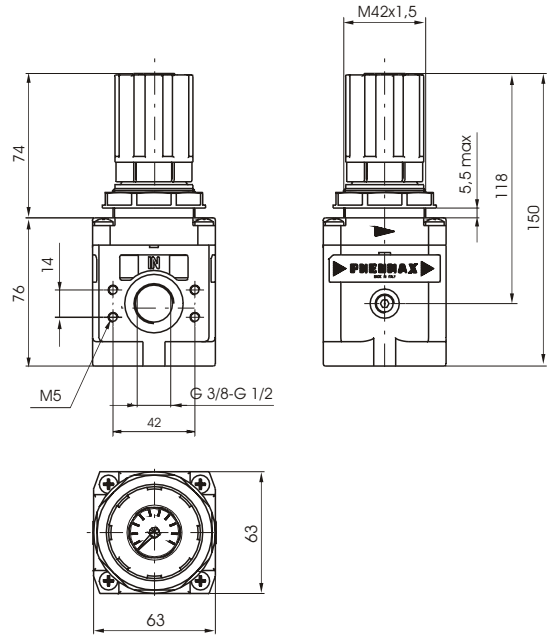

**Construction and working characteristics**

- Diaphragm pressure regulator with relieving.
- Pressure gauge included on the top of adjusting knob.
- Balanced poppet.
- Lockable handle by simply pressing it downwards in the desired position.
- Body made with light alloy.
- Wall mounting possibility with M5 screws protected by covers.
- Panel mounting bracket.

**Technical characteristics**

Connections	G 3/8" - G 1/2"
Max. inlet pressure	13 bar - 1,3 MPa
Max. ambient temperature	50°C
Pressure gauge connections	G 1/8"
Weight	gr. 600
Pressure range	0 - 2 bar
	0 - 4 bar
	0 - 8 bar
	0 - 12 bar
Assembly position	Any
Wall fixing screws	M5
Max. fitting torque	40 Nm

Flow rate curves  
 Inlet pressure (7 bar)

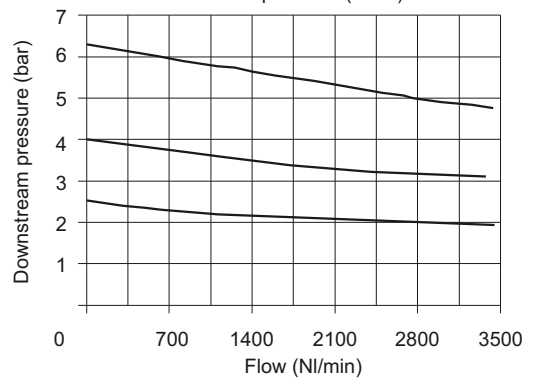

Adjustment characteristics

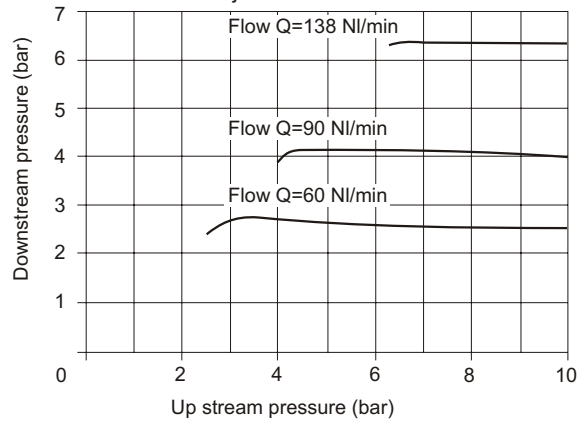

Ordering code

**17322**

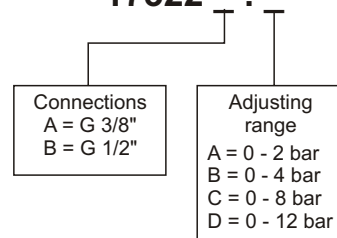

Example: **17322A.C**  
 Pressure regulator with G 3/8" connections, adjusting range 0 - 8 bar with relieving.

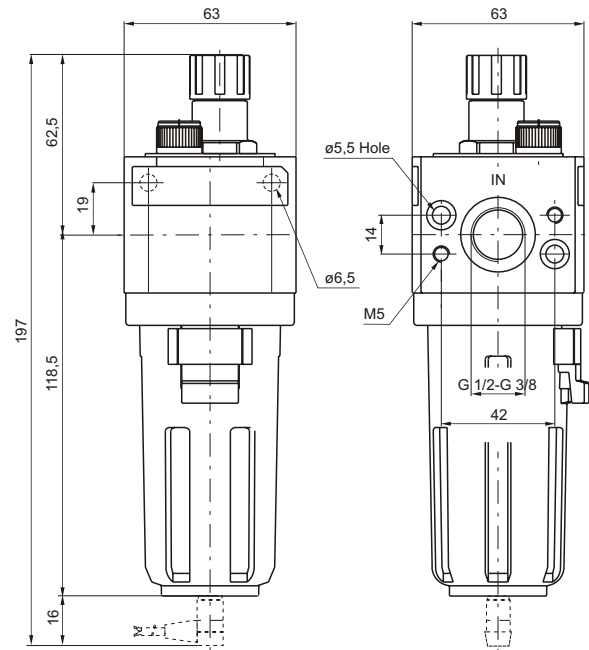

### Construction and working characteristics

- Fog type lubrication with variable section orifice according to the flow.
- Body made with light alloy.
- Wall mounting possibility with M5 screws protected by covers.
- Transparent technopolymer bowl with shock resistant technopolymer protection
- Possibility to see the min. and max. level on 360° also with bowl protection assembled.
- Bowl assembled to the body with bayonet cap and safety button.
- Transparent technopolymer sight dome with adjusting handle.
- Oil filling plug.
- Electrical connector for low level indication. Use the C1, C2 or C3 lead for connection ( see section 8, catalogue 4 "Cylinders").

### Technical characteristics

Connections	G 3/8" - G 1/2"
Max. inlet pressure	13 bar - 1,3 MPa
Max. ambient temperature (at 10 bar)	50°C
Weight	gr. 435
Indicative oil drip rate	1 drop every 300/600 NI
Oil type	FD22 - HG32
Bowl capacity	80 cm <sup>3</sup>
Assembly position	Vertical
Wall mounting screws	M6
Min. operational flow	20 NI/min
Max. fitting torque	40 Nm

Flow rate curves

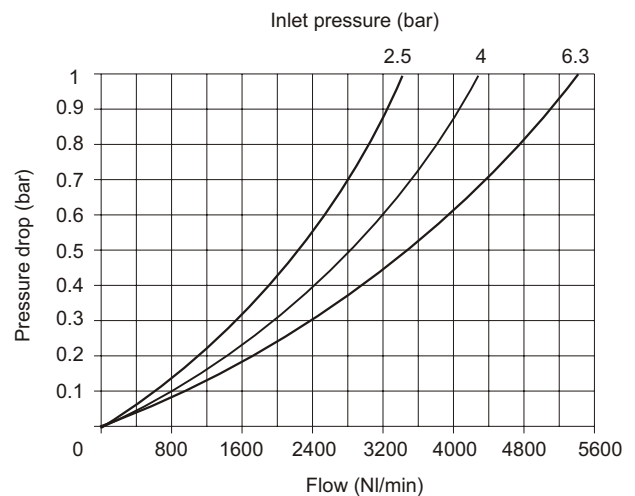

### Ordering code

**17303**

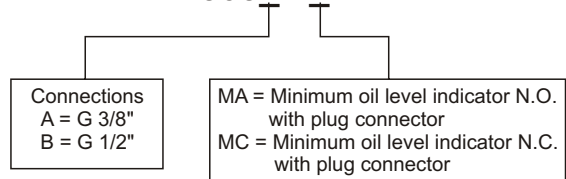

Note: on MA version the contact is open when the bowl is filled  
on MC version the contact is closed when the bowl is filled

Example: **17303A**  
Lubricator with G 3/8" connections.



### Construction and working characteristics

- Filter - diaphragm pressure regulator with relieving.
- Balanced poppet.
- Lockable handle by simply pressing it downwards in the desired position.
- Body made with light alloy.
- Wall mounting possibility with M6 screws protected by covers.
- Double filtering action: by air centrifuging and by replaceable and reusable HDPE porous filter element.
- Transparent technopolymer bowl with shock resistant technopolymer protection connected to the body with bayonet cap and safety button.
- Manual and semi-automatic water drain valve; in the semiautomatic version the drainage happen when there is no pressure or by pushing the valve up-wards.
- Possibility to see the water level on 360° also with bowl protection assembled.
- Automatic water drainage bowl available on request.
- Two pressure gauge connections with plug complete of seal.

### Technical characteristics

Connections	G 3/8" - G 1/2"
Max. inlet pressure	13 bar - 1,3 MPa
Max. ambient temperature (at 10 bar)	50°C
Pressure gauge connections	G 1/8"
Weight	gr. 645
Pressure range	0 - 2 bar
	0 - 4 bar
	0 - 8 bar
	0 - 12 bar
Filter pore size	5µ
	20µ
	50µ
Blow capacity	42 cm <sup>3</sup>
Assembly position	Vertical
Wall mounting screws	M6
Max. fitting torque	40 Nm

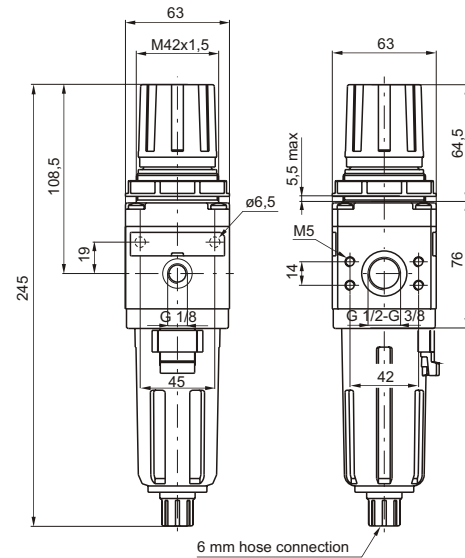

Flow rate curves  
Inlet pressure (7 bar)

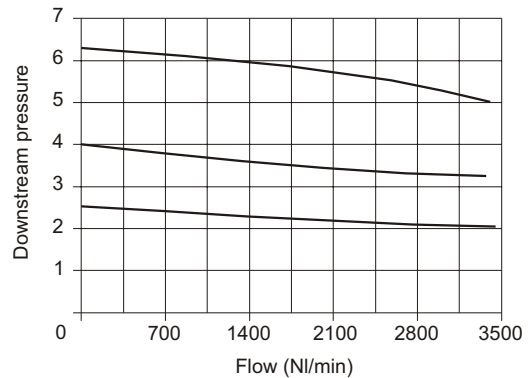

Adjustment characteristics

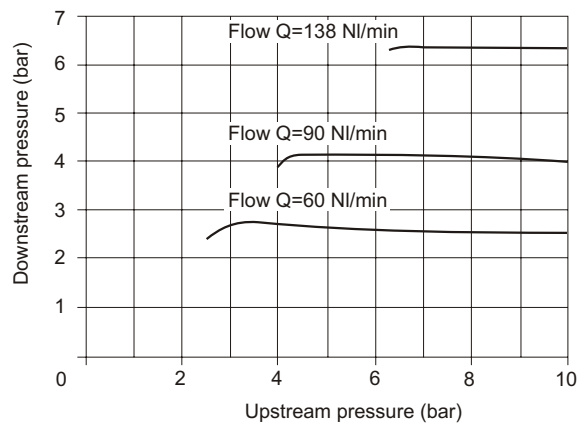

Ordering code

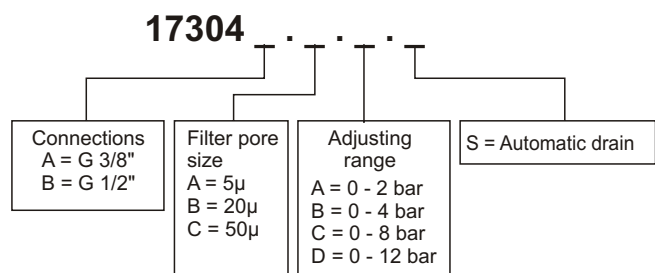

Example: **17304A.B.C**  
Filter - pressure regulator size 3 with G 3/8" connections, filter pore size 20µ and adjusting range 0-8 bar

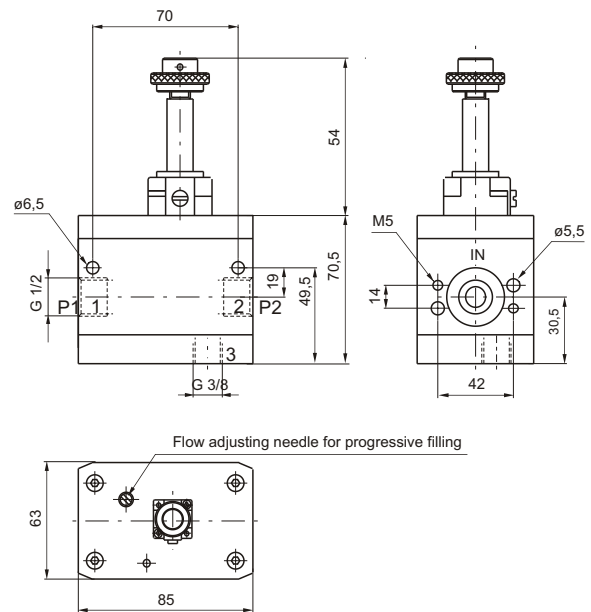
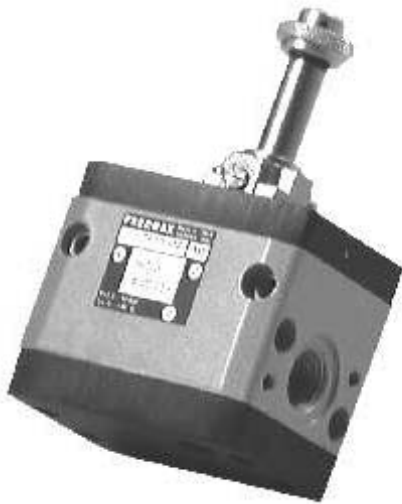

### Construction and working characteristics

- 3 way valve with double poppet.
- Possibility to adjust the down stream circuit filling time by the enclosed adjustable metering screw.
- Quick down stream circuit discharge.
- Possibility for a pneumatic or electric piloting control.
- Body made with anodized 2011 aluminum alloy.
- Wall mounting possibility with M6 screws.

**Important note:** the preventive or programmed maintenance of this product is not foreseen considering the elaborated assembling and the specific "PNEUMAX" testing; therefore, call the producer or its representative in case of necessity.

### Technical characteristics

Connections	G 1/2"
Max. inlet pressure	10 bar - 1 MPa
Max. ambient temperature	50°C
Weight	gr. 1010
Assembly position	Any
Wall mounting screws	M6
Min. operating pressure	2.5 bar - 0.25 Mpa
Nominal flow at 6 bar with $D_p=1$	2500 NI/min
Flow with adjustable metering screw fully open	340 NI/min

Ordering code

### 17310.M2

Electrically controlled progressive start-up valve size 3, complete with mechanic for M2 microsolenoid valve.

### 17320

Progressive start-up valve size 3 with pneumatic control.

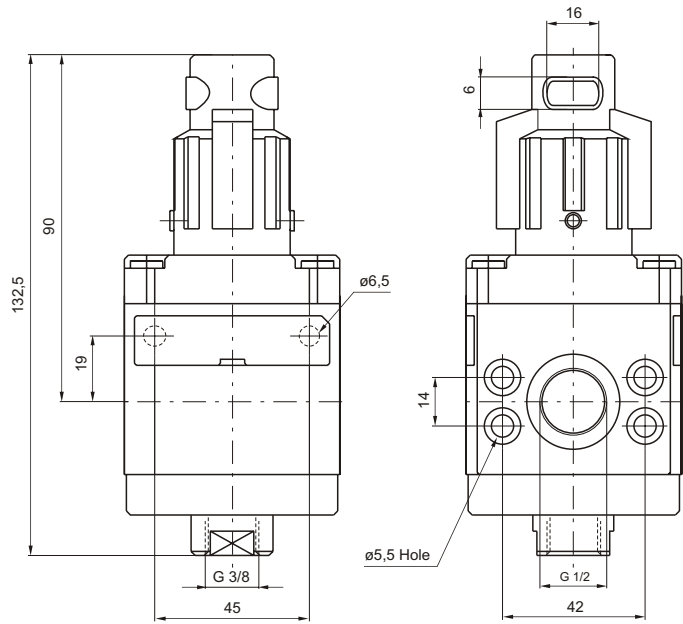

### Construction and working characteristics

- 3 ways poppet valve.
- Body made with light alloy.
- Wall mounting possibility with M6 screws protected by covers.
- Double action handle for valve opening: pushing and rotating (clockwise).
- Simple rotate the valve handle counter clockwise for valve closing and down stream circuit discharging.
- Possibility to lock the valve in the discharging position by fitting in a padlock in the proper seat.

### Technical characteristics

Connections	G 1/2"
Max. inlet pressure	13 bar - 1,3 MPa
Max. ambient temperature	50°C
Weight	gr. 550
Assembly position	Any
Nominal flow at 6 bar with $D_p=1$	2500 NI/min
Wall mounting screws	M6
Handle opening and closing angle	90°
Max. fitting torque	40 Nm

**Important note:** the preventive or programmed maintenance of this product is not foreseen considering the elaborated assembling and the specific "PNEUMAX" testing; therefore, call the producer or its representative in case of necessity.

### Ordering code

**17330 .**

A = Not lockable handle  
B = Lockable handle  
M2 = Electric with M2  
M2/9 = Electric with M2/9  
PN = Pneumatic

Example: **17330.B**  
Shut-off valve size 3 complete with lockable handle.



### Construction and working characteristics

- Filter - diaphragm pressure regulator with relieving.
- Balanced poppet.
- Double filtering action: by air centrifuging and by replaceable and reusable HDPE porous filter element.
- Body made with light alloy.
- Wall mounting possibility with M6 screws protected by covers.
- Lockable handle by simply pressing it downwards in the desired position.
- Transparent technopolymer bowl with shock resistant technopolymer protection connected to the body with bayonet cap and safety button.
- Manual and semi-automatic water drain valve; in the semi-automatic version the drainage happens when there is no pressure or by pushing the valve up-wards.
- Possibility to see the water level on 360° also with bowl protection assembled.
- Automatic water drainage bowl available on request.
- Two pressure gauge connections with plug complete of seal.
- Fog type lubrication with variable section orifice according to the flow.
- Transparent technopolymer sight dome with adjusting handle.
- Oil filling plug.

### Technical characteristics

Connections	G 3/8" - G 1/2"
Max. inlet pressure	13 bar - 1,3 MPa
Max. ambient temperature (at 10 bar)	50°C
Pressure gauge connections	G 1/8"
Weight	gr. 1100
Pressure range	0 - 2 bar 0 - 4 bar 0 - 8 bar 0 - 12 bar
Filter pore size	5µ 20µ 50µ
Bowl capacity	42 cm <sup>3</sup>
Oil type	FD22 - HG32
Indicative oil drip rate	1 drop every 300/600 NI
Bowl capacity	80 cm <sup>3</sup>
Min. operational flow at 6,3 bar	20 NI/min
Assembly position	Vertical
Wall mounting screws	M6
Max. fitting torque	40 Nm

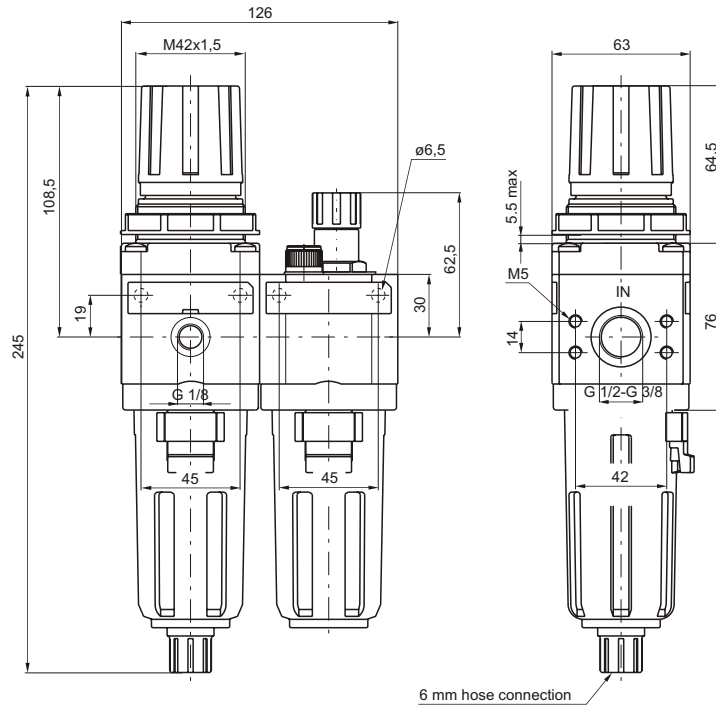

Flow rate curves  
 Inlet pressure (7 bar)

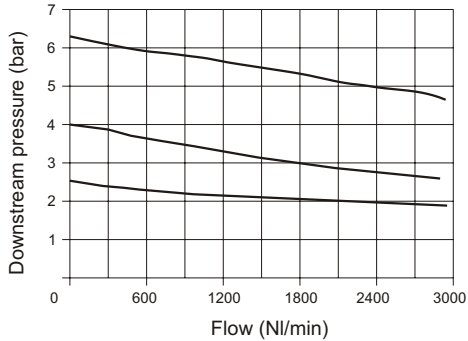

Adjustment characteristics

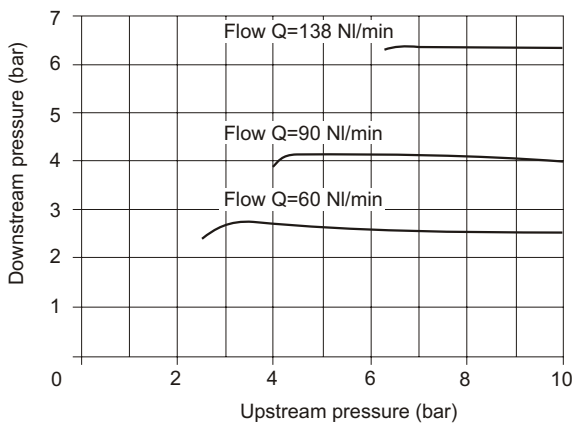

Ordering code

**17306**

Connections A = G 3/8" B = G 1/2"	Filter pore size A = 5µ B = 20µ C = 50µ	Adjusting range A = 0 - 2 bar B = 0 - 4 bar C = 0 - 8 bar D = 0 - 12 bar	S = Automatic drain
---	--	--	---------------------

Example: **17306A.B.C.S**

Service unit combination complete with filter - pressure regulator + lubricator size 3.  
 G 3/8" connections, filter pore size 20µ, adjusting range 0-8 bar and automatic drain.



### Construction and working characteristics

- Filter - diaphragm pressure regulator with relieving.
- Double filtering action: by air centrifuging and by replaceable and reusable HDPE porous filter element.
- Body made with light alloy.
- Wall mounting possibility with M6 screws protected by covers.
- Pressure adjusting lockable handle by simply pressing it downwards in the desired position.
- Transparent technopolymer bowl with shock resistant technopolymer protection connected to the body with bayonet cap and safety button.
- Manual and semi-automatic water drain valve; in the semi-automatic version the drainage happens when there is no pressure or by pushing the valve up-wards.
- Automatic water drainage bowl available on request.
- Possibility to see the water level on 360° also with bowl protection assembled.
- Two pressure gauge connections with plug complete of seal.
- Fog type lubrication with variable section orifice according to the flow.
- Transparent technopolymer sight dome with adjusting handle.
- Oil filling plug.

### Technical characteristics

Connections	G 3/8" - G 1/2"
Max. inlet pressure	13 bar - 1,3 MPa
Max. ambient temperature (at 10 bar)	50°C
Pressure gauge connections	G 1/8"
Weight	gr. 1430
Pressure range	0 - 2 bar 0 - 4 bar 0 - 8 bar 0 - 12 bar
Filter pore size	5µ 20µ 50µ
Bowl capacity	42 cm <sup>3</sup>
Oil type	FD22 - HG32
Indicative oil drip rate	1 drop every 300/600 NI
Bowl capacity	80 cm <sup>3</sup>
Min. operational flow at 6,3 bar	20 NI/min
Assembly position	Vertical
Wall mounting screws	M6
Max. fitting torque	40 Nm

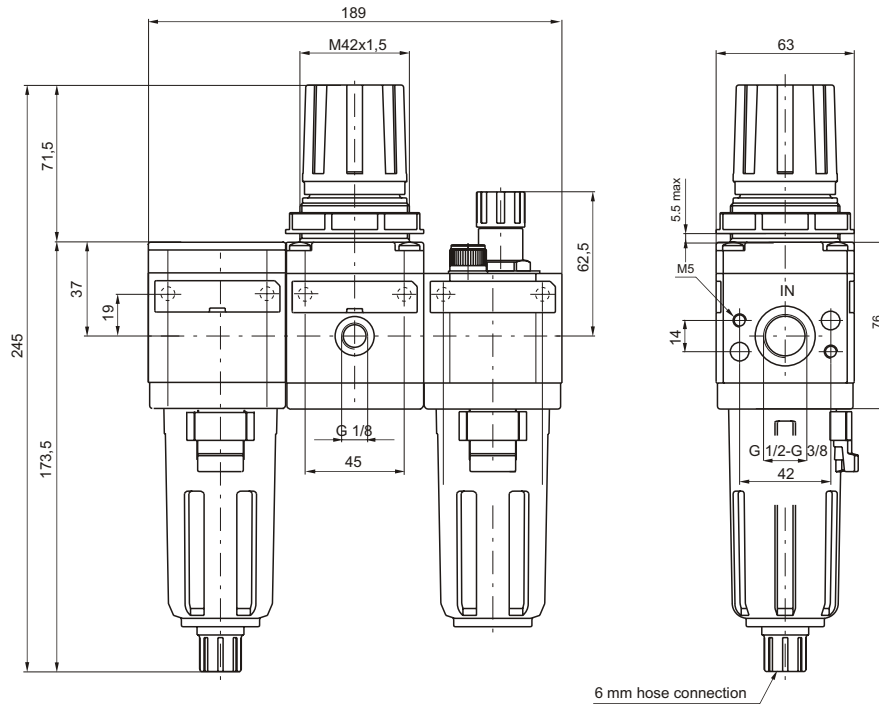

Flow rate curves  
Inlet pressure (7 bar)

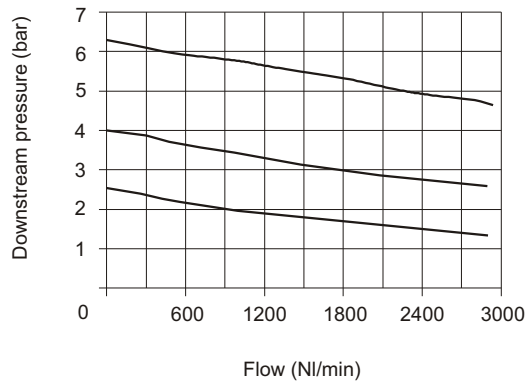

Adjustment characteristics

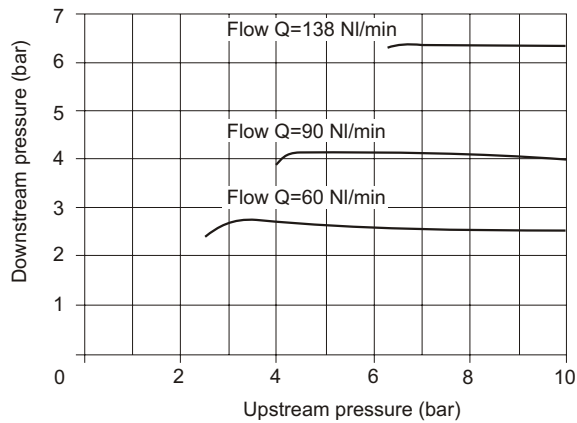

Ordering code

**17307**

Connections A = G 3/8" B = G 1/2"	Filter pore size A = 5μ B = 20μ C = 50μ	Adjusting range A = 0 - 2 bar B = 0 - 4 bar C = 0 - 8 bar D = 0 - 12 bar	S = Automatic drain
---	--	--	---------------------

Example: **17307A.B.C.S**

Service unit combination complete with filter - pressure regulator and lubricator size 3.

G 3/8" connections, filter pore size 20μ, adjusting range 0-8 bar and automatic drain.