



Construction and working characteristics

- Zinc alloy body or reinforced technopolymer body with threaded brass insert connections.
- Wall mounting possibility with M4 screws protected by covers.
- Transparent technopolymer bowls screwed to the body.
- Shock resistant bowl technopolymer protections.
- Double filtering action: by air centrifuging and by replaceable and reusable HDPE porous filter element.
- Manual and semi-automatic water drain valve; in the semi-automatic version the drainage happens when there is no pressure or by pushing the valve up-wards.
- Possibility to see the water level on 360° also with bowl protection assembled.
- Diaphragm pressure regulator with relieving and balanced poppet.
- Pressure adjusting lockable handle by simply pressing it downwards in the desired position.
- Two pressure gauge connections with plug complete of seal.
- Panel mounting bracket.
- Automatic water drainage bowl available on request.
- Fog type lubrication with variable section orifice according to the flow.
- Possibility to see the min. and max. oil level on 360° also with bowl protection assembled.
- Transparent technopolymer sight dome with adjusting handle.
- Oil filling plug.

Technical characteristics

Connections	G 1/8" - G 1/4"
Max. inlet pressure	13 bar - 1,3 MPa
Max. ambient temperature (at 10 bar)	50°C
Pressure gauge connections	G 1/8"
Weight with technopolymer body	gr. 375
Weight with zinc alloy body	gr. 755
Pressure range	0 - 2 bar 0 - 4 bar 0 - 8 bar 0 - 12 bar
Filter pore size	5µ 20µ 50µ
Bowl capacity	17 cm ³
Indicative oil drip rate	1 drop every 300/600 NI
Oil type	FD22 - HG32
Bowl capacity	32 cm ³
Assembly position	Vertical
Wall mounting screws	M4
Max. fitting torque on zinc alloy body	30 Nm
Max. fitting torque on technopolymer body	15 Nm
Min. operational flow at 6.3 bar	10 NI/min

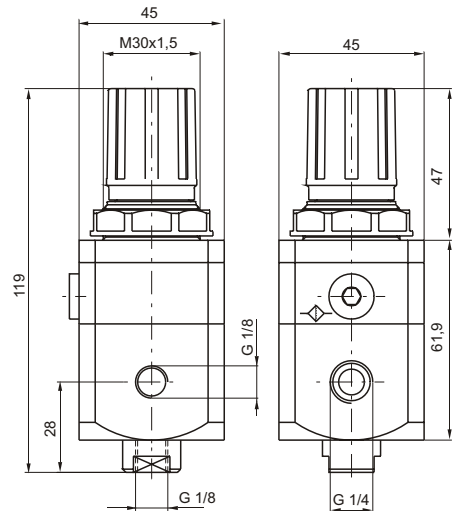

Construction and working characteristics

- Accurate capacity to maintain set pressure.
- Sensitivity combined with high relieving rates.
- High flow rate with extremely low pressure drop.
- Pressure adjusting lockable handle by simply pressing it downwards in the desired position.
- Body made with anodized zoll aluminium alloy
- Two pressure gauge connections with plug complete of seal.
- Ring nut for panel mounting.
- Once set, a constant bleed of air maintains the accuracy of the regulator.
This controlled release is a charasteric, not a fault.

Technical characteristics

Connections	G 1/4"
Max. inlet pressure	10 bar - 1 MPa
Max. ambient temperature	50°C
Pressure gauge connections	G 1/8"
Weight	gr. 350
Pressure range	0,1 - 2 bar 0,1 - 4 bar 0,1 - 7 bar
Assembly position	Any
Air flow (inlet pressure 10 bar)	5 NI/min
Max. fitting torque	40 Nm
Fluid	20µm filtered air and preferably non lubricated

Ordering code

17112B .

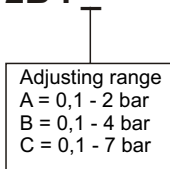

Example: **17112B.C**
Pressure regulator with G 1/4" 0,1 - 7 bar

Flow rate curves (17112B.C)
Inlet pressure (7 bar)

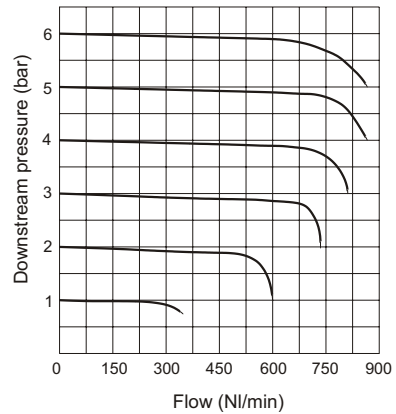

Adjustment characteristics (17112B.C)

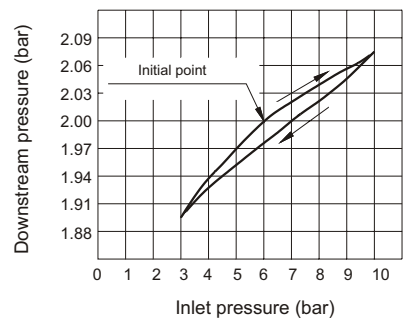

Exhaust flow rate curves (17112B.C)

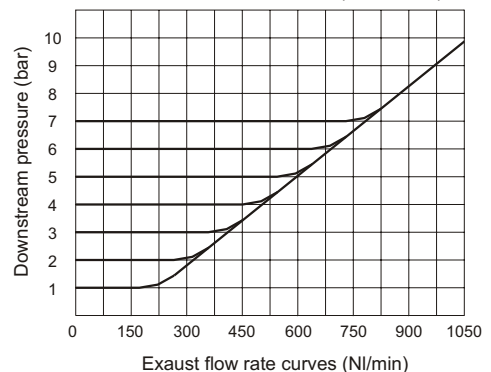

Pressure Switch complete with adapter

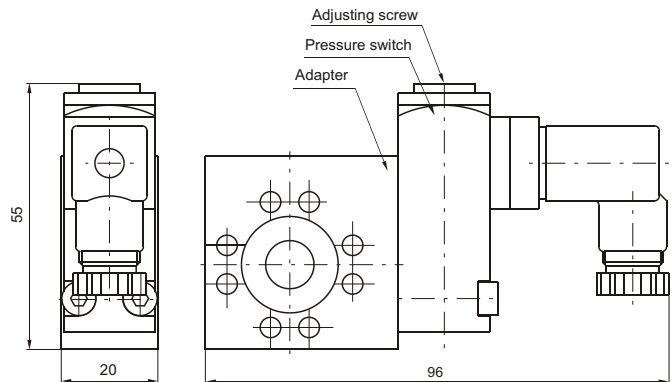

Construction and working characteristics

The pressure switch complete with adapter has to be assembled between two elements of the FRL group. It cannot be utilized separately or at the end of the FRL group.

The pressure switch can be set at desired pressure (pressure range from 2 to 10 bar) by rotating the adjusting screw.

The electrical connection is made by mean of a 15 mm connector DIN 43650 type C.

The microswitch contact could be normally closed or open (change over switch).

Connection

- 1 = Neutral
- 2 = N.C. contact
- 3 = N.O. contact

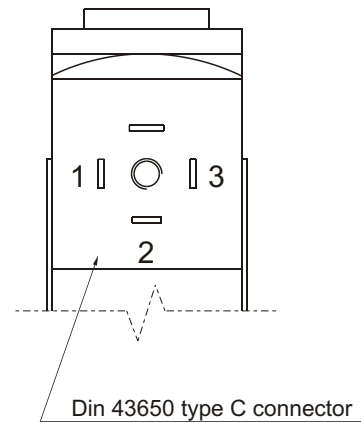

Technical characteristics

Max. inlet pressure	13 bar 1.3 MPa
Max. temperature	50°C
Weight	gr. 160
Microswitch capacity	5A
Grade of protection (with connector assembled)	IP 65
Adjusting range	2 - 10 bar
Assembly position	Any

Ordering code

17

- 14A = Pressure switch adapter
- 14B = Pressure switch
- 14C = Pressure switch complete with adapter

Example: **1714C**
Pressure switch complete with adapter.



Air Intake

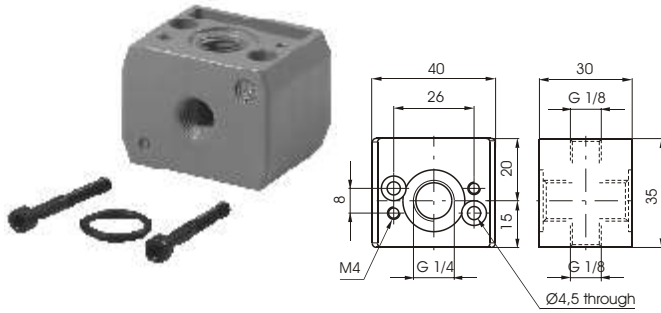

Ordering code

17140

Weight gr. 75

Air Intake - "H" profile

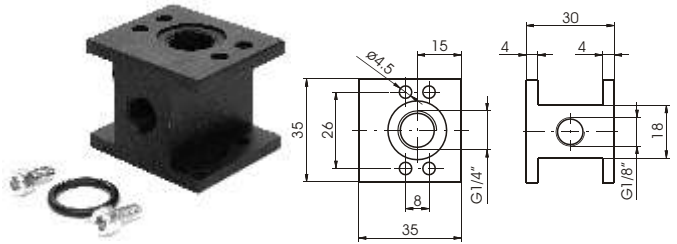

Ordering code

17140H

Weight gr. 50

Fixing bracket

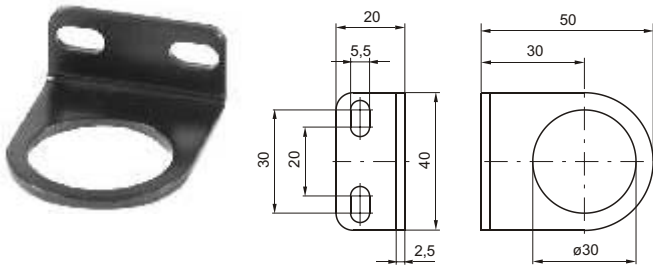

Ordering code

17150

Weight gr. 32

Fixing bracket

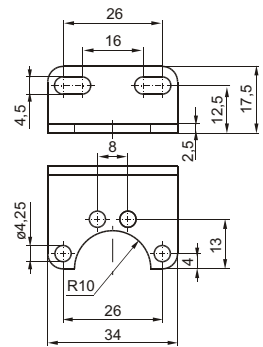

Ordering code

170M5

Weight gr. 20

Assembling kit



Ordering code

17160

(standard)

17165

(for progressive start-up valve)

Weight gr. 15

Assembling kit for manifold regulators



Ordering code

170M6

Weight gr. 20

Pressure gauge

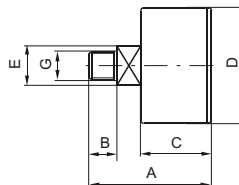

Ordering code

17070

A = Dial ø40
B = Dial ø50

A = Scale 0-4 bar
B = Scale 0-6 bar
C = Scale 0-12 bar

DIMENSIONS							
CODE	A	B	C	D	E	G	Weight gr.
17070A	44	10	26	41	14	G 1/8"	60
17070B	45	10	27	49	14	G 1/8"	80

Filter

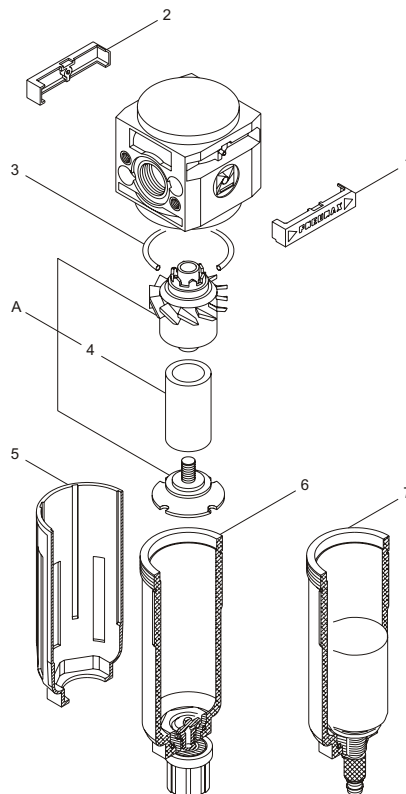

Pos.	Code	Description
1	RS/1701/10	Front tab
2	RS/1701/11	Rear tab
3	RS/OR 2125	Seal
4	RS/1701/13	Porous filter element 20 μ
4	RS/1701/52	Porous filter element 5 μ
4	RS/1701/53	Porous filter element 50 μ
5	RS/1701/7	Bowl protection
6	RK1701A/013	Filter bowl c/w drain valve
7	RK1701A/018	Filter bowl c/w automatic drain
A	RK1701A/014	Filter group assembly 20 μ
A	RK1701A/021	Filter group assembly 5 μ
A	RK1701A/022	Filter group assembly 50 μ

Coalescing filter

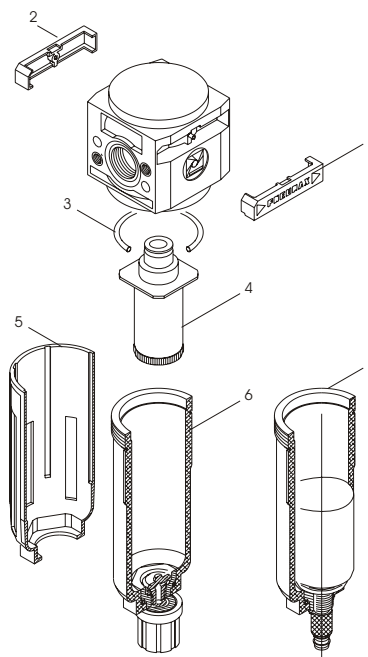

Pos.	Code	Description
1	RS/1701/93	Front tab
2	RS/1701/94	Rear tab
3	RS/OR 2125	Seal
4	RK1701A/027	Coalescent group 0.1 μ
5	RS/1701/7	Bowl protection
6	RK1701A/013	Filter bowl c/w drain valve
7	RK1701A/018	Filter bowl c/w automatic drain

Panel mounting pressure regulator

Pos.	Code	Description
1	RS/1701/12	Lock nut
2	RS/1701/3	Adjusting knob
3	RS/1701/2	Adjusting support
4	RK1701A/016	Adjusting screw assembly
5	RS/1701/30	Spring 0-2 bar range
5	RS/1701/29	Spring 0-4 bar range
5	RS/1701/28	Spring 0-8 bar range
5	RS/1701/31	Spring 0-12 bar range
6	RK1701A/012	Diaphragm assembly
6	RK1701A/024	Diaphragm assembly w/o relieving
7	RK1701A/023	Nozzle c/w poppet
8	RK1701A/020	Plug c/w seal G 1/8

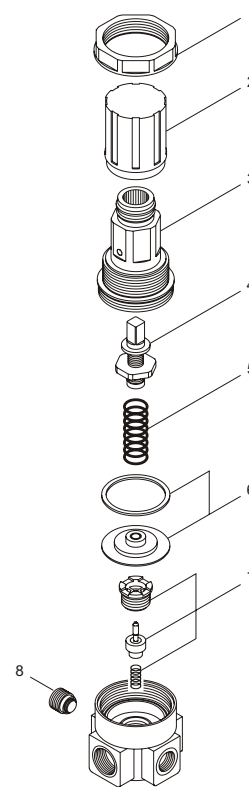

Modular pressure regulator

Pos.	Code	Description
1	RS/1701/12	Lock nut
2	RS/1701/3	Adjusting knob
3	RS/1701/2	Adjusting support
4	RK1701A/016	Adjusting screw assembly
5	RS/1701/30	Spring 0-2 bar range
5	RS/1701/29	Spring 0-4 bar range
5	RS/1701/28	Spring 0-8 bar range
5	RS/1701/31	Spring 0-12 bar range
6	RK1701A/012	Diaphragm assembly
6	RK1701A/024	Diaphragm assembly w/o relieving
7	RS/1701/11	Rear tab
8	RK1701A/020	Plug c/w seal G 1/8
9	RS/1701/10	Front tab
10	RK1701A/025	Poppet c/w spring
11	RS/OR 2125	Seal
12	RS/1701/32	Plug

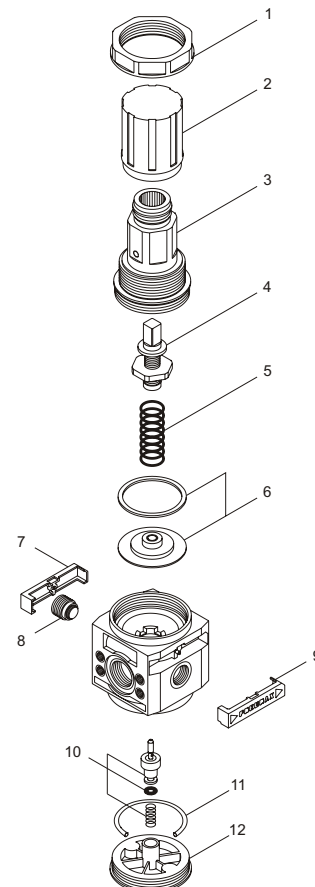

Lubricator

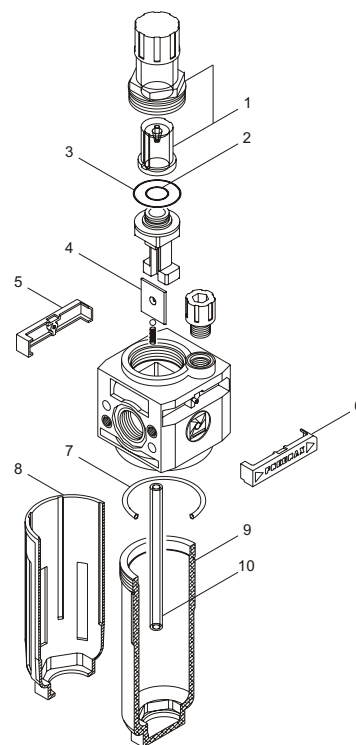

Pos.	Code	Description
1	RK1701A/026	Lubricator sight dome assembly
2	RS/OR 5x1,5	Seal
3	RS/OR 2075	Seal
4	RS/1701/43	Venturi diaphragm
5	RS/1701/11	Rear tab
6	RS/1701/10	Front tab
7	RS/OR 2125	Seal
8	RS/1701/7	Bowl protection
9	RS/1701/41	Lubricator bowl
10	RS/1701/47	Oil tube

Filter - Pressure regulator

Pos.	Code	Description
1	RS/1701/12	Lock nut
2	RS/1701/3	Adjusting knob
3	RS/1701/2	Adjusting support
4	RK1701A/016	Adjusting screw assembly
5	RS/1701/30	Spring 0-2 bar range
5	RS/1701/29	Spring 0-4 bar range
5	RS/1701/28	Spring 0-8 bar range
5	RS/1701/31	Spring 0-12 bar range
6	RK1701A/012	Diaphragm assembly
6	RK1701A/024	Diaphragm assembly w/o rel.
7	RS/1701/11	Rear tab
8	RK1701A/020	Plug c/w seal G 1/8
9	RS/1701/10	Front tab
10	RK1701A/025	Poppet c/w seal and spring
11	RS/OR 2125	Seal
12	RS/1701/13	Porous filter element 20µ
12	RS/1701/52	Porous filter element 5µ
12	RS/1701/53	Porous filter element 50µ
13	RS/1701/7	Bowl protection
14	RK1701A/013	Filter bowl c/w drain valve
15	RK1701A/018	Filter bowl c/w automatic drain
A	RK1701A/014	Filter group assembly 20µ
A	RK1701A/021	Filter group assembly 5µ
A	RK1701A/022	Filter group assembly 50µ

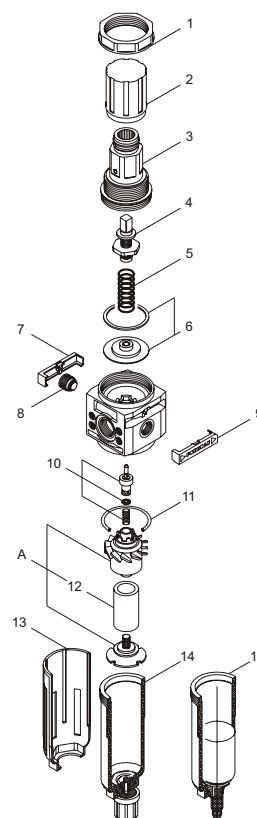

1